



*Phantom Racing Chassis®*



## Owner's Manual

Your Serial Number:

---

Please have this number ready when/if you call for setup or tech help. Thanks!

*Please read and understand this manual  
before assembling or using this product.*

Remember, racing is a dangerous sport. Wiggins Kart Shop, Inc. and/or Phantom Racing Chassis® is not liable for injuries that may occur while using any products we sell and/or manufacture. The final decision of the safety and use of any product is the sole responsibility of the user. The user accepts all responsibility. All products that are sold by Wiggins Kart Shop, Inc. and/or Phantom Racing Chassis® are intended for professional racing only.



# TABLE OF CONTENTS

<b>1.0 INSPECTION OF NEW CHASSIS .....</b>	<b>5</b>
<b>2.0 CUSTOMER CHECKLIST .....</b>	<b>5-6</b>
2.1 <i>Deuce™ Standard Package</i>	
2.2 <i>Deuce™ Champion's Edition™ Package</i>	
2.3 <i>Deuce™ Elite Edition™ Package</i>	
<b>3.0 BASIC OVERVIEW OF ASSEMBLY.....</b>	<b>7-11</b>
3.1 <i>Steering Support</i>	
3.2 <i>Steering Wheel Mounting</i>	
3.3 <i>Seat Mounting</i>	
3.4 <i>Body Work Mounting</i>	
3.5 <i>Other Hardware Mounting</i>	
<b>4.0 DEUCE™ SETUP INFORMATION .....</b>	<b>12-15</b>
4.1 <i>Deuce™ Caster Information</i>	
4.2 <i>Deuce™ Camber Information</i>	
4.3 <i>Deuce™ RF &amp; LF Adjustable Lead</i>	
4.4 <i>Rear Cassette "Quick Release" Pins</i>	
4.5 <i>Weight Out Information</i>	
4.6 <i>Recommended Starting Setups</i>	
<b>5.0 BEARING MAINTENANCE .....</b>	<b>16-17</b>
5.1 <i>PRC® Performance Rear Axle Bearings</i>	
5.2 <i>Front Hub Bearings</i>	
5.3 <i>Kingpin Bearings</i>	
<b>6.0 BRAKE INSPECTION AND MAINTENANCE .....</b>	<b>18</b>
6.1 <i>Bleeding Instructions</i>	
<b>8.0 ADDING BALLAST WEIGHT (LEAD).....</b>	<b>19</b>
<b>9.0 PAINT CARE AND CLEANING .....</b>	<b>19</b>
<b>10.0 BENT OR BROKEN PARTS .....</b>	<b>19</b>
<b>11.0 PERFORMANCE.....</b>	<b>20</b>
<i>Recommended Tire and Wheel Sizes</i>	
<b>12.0 SERIAL NUMBERS .....</b>	<b>20</b>

## RESOURCES:

*Gear Ratio Chart.....22*

*Phantom® Note Pad.....23-24*



## ***Introduction***

Congratulations on the purchase of your new Phantom Racing Chassis®. We pride ourselves in providing our customers with the necessary information to allow them to run up front. This owner's manual is another step in the learning process and hopefully you will find this manual informative.

This manual contains valuable information on the inspection, assembly, set up, and maintenance of your new chassis. Please do not take sections of this manual for granted, all are equally important. Whether you are a new racer or a seasoned veteran, this manual can help you. Thanks again for your patronage and most of all... Good luck!

*DISCLAIMER:* Please remember, racing is a dangerous sport. Wiggins Kart Shop, Inc. and/or Phantom Racing Chassis® is not liable for injuries that may occur while using any products we sell and/or manufacture. The final decision of the safety and use of any product is the responsibility of the user. The user accepts all responsibilities.

This booklet and all information contained therein are copyright of Wiggins Kart Shop, Inc. and Phantom Racing Chassis®. Any republication of this document without written consent from Wiggins Kart Shop, Inc. and Phantom Racing Chassis® is prohibited.

All Logos and Item Names used by Wiggins Kart Shop, Inc. and Phantom Racing Chassis® are under Trademark and/or registered Trademarks of Wiggins Kart Shop, Inc. and/or Phantom Racing Chassis. Any use of these Logos or Item names without written consent from Wiggins Kart Shop, Inc. and Phantom Racing Chassis® is Prohibited.

***Warranty: Wiggins Kart Shop, Inc. and/or Phantom Racing Chassis® known henceforth as "seller" MAKES NO WARRANTY OF ANY KIND, EXPRESS OR IMPLIED, except that the goods sold under this agreement shall be of the standard quality of seller, and buyer assumes all risk and liability resulting from the use of the goods, whether used singly or in combination with other goods. Seller neither assumes nor authorizes any person to assume for seller any other liability in connection with the sale or use of the goods sold, and there are no oral agreements or warranties collateral to or affecting this agreement.***

## 1.0 INSPECTION OF NEW CHASSIS

Before you start assembling your chassis, please take some time to first inspect it for any damaged, missing or defective parts. Granted, we do everything possible to ensure that every chassis that goes out the door is perfect but we are human and we make mistakes.

### *Equipment*

Depending upon what chassis and package you purchased, standard and optional equipment will vary. Look over your kart and make sure you have everything you paid for. If you are unsure of something, please call your dealer or Phantom® and inquire because now is the time to let us know.

### *What to inspect*

Be sure to inspect your kart for all the required safety features such as safety pins in all the sanction-required places, brakes, all fasteners, etc. Take added time to inspect the complete brake system. First, inspect around all fittings and the complete system for any fluid that may have leaked during shipping. Check to make sure that the fluid reservoir is full. Next, pump the brake pedal to make sure the system is working properly and there is no air in the lines. Last but certainly not least, check to make sure all fasteners in the complete brake system are properly installed and tight. *For more details about your brake system, see section 6.0 on Brakes.*

Inspect all components of the steering system. After the steering upright is installed in race position, turn the steering system to it's full extents and make sure the system is free of any binding or loose motion. Inspect all fasteners and safety pins to insure they are properly installed and tight.

Finish your inspection by inspecting all bumpers, nerf bars, pedal assemblies and brackets. Be sure to check all fasteners, pins and clips to make sure they are in good condition and installed properly. From here, use your best discretion to determine the overall safety and workmanship of the chassis. If you are not satisfied with anything about your chassis, call your dealer or Phantom®.

## 2.0 CUSTOMER CHECKLISTS

### *2.2 Deuce™ Standard Package*

This is what you should receive with your standard Deuce™ kart package.

- PRC® performance bearings
- Lightweight hubs with press-in, bullet end studs
- PRC® “Tilt” steering wheel
- NeXgen Seat™
- Set of seat struts and bottoms
- Accutoe™ steering lock kit
- R15 & L7.5 caster blocks
- Steering shaft
- Steering upright and steering yoke
- Splined steering hub
- Fasteners for the steering shaft, steering upright, steering wheel, seat and gear hub
- Owner’s manual
- Registration card
- Miscellaneous info & decals

## ***2.2 Deuce™ Champion's Edition™ Package***

This is what you should receive with your Deuce™ Champion's Edition™ package Standard Edition components plus the following:

- Complete body kit with driver's bubble & bracket
- Complete Dzus body bolt kit
- Complete "Flip" Mega Mount™

## ***2.3 Deuce™ Elite Edition™ Package***

This is what you should receive with your Deuce™ Elite Edition™ package.

Standard & Champion's Edition™ components with the following upgrades:

- PRC® Ceramic bearings for front hubs and rear axle
- PRC® Ceramic bearing oil
- 3 pre-installed axle collars
- Phantom pedal grips
- Floating gear hub (Xcel hub optional)
- PRC® chain guide assembly
- Lightweight aluminum rod ends
- Lightweight aluminum spindle nuts
- APC Right Side Hubs

*If you did not receive everything on the list for the package you purchased, please contact your dealer. If the problem is still not resolved, please contact PRC®.*

## 3.0 BASIC OVERVIEW OF ASSEMBLY

### 3.1 Steering Support/ Upright

#### *Single Post Design*

Your Phantom® chassis is equipped with a single post design steering support. Chances are, when you received your chassis the steering support was in the shipping position. It is very important that the steering support is properly installed and aligned during final assembly. To ensure you properly align your steering assembly, follow this simple procedure. If you have any problems, contact your local dealer or Phantom® for assistance.

*In your kart kit, you will find a bag that contains your steering components such as the steering upright, upper steering block, & yoke to hold the steering block and the misc. required fasteners.*

1. First install the ½-20 jam nut on the ½-20 x 1 ½” bolt of the upper steering yoke and screw the steering yoke into the steering post. Be sure to use the jam nut and to screw the yoke *at least ½”* into the upright.

*TIP: Before installing the steering yoke into the steering upright post now is a good time to apply some anti-seize compound to the threads. This is not required but may save you a headache down the road with future maintenance.*

2. Place the steering post over the frame and install the ¼-28 x 1 ½” bolt. To do this, install the hex-screw through the upright and frame. Next install the ¼” flat washer and the ¼-28 Nylon lock nut and securely tighten. Don’t forget the cotter pin!
3. Install the steering shaft (machined end, not splined end) into the ½” rod end in the lower steering support and install the ½” AN washer and ½-20 slotted hex nut. Also, install the upper steering block on the steering shaft. Raise the steering shaft to the desired height and install the 5/16”-24 x 2 ¼” hex head bolt with a 5/16” flat washer under the head of the bolt through the steering yolk and steering block. Use one 5/16 SAE flat washer and 5/16-24 NLN.

*TIP: If you are going to utilize a bubble bracket, install the bracket at this time and snug the bolt assembly. If you are not adding a bubble bracket, tighten these bolts and install the cotter pin.*

4. Before you install the tie rods to the steering shaft, note how the bolt assembly is installed. There are four (4) 3/8” AN washers between the pitman arms. Two washers go between the top rod end and the pitman arm and the other two go between the bottom rod end and the pitman arm. *No washers go between the two rod ends!* One 3/8” SAE flat washer goes under the 3/8-24 x 2” HHCS bolt head and one under the 3/8-24 slotted hex nut. This assembly method will provide you with maximum steering travel and performance.
5. Install and tighten the tie rod assemblies with the short left side tie rod on the top position between the pitman arms. (at end)

*TIP: Be sure not to over tighten the pitman arm bolt assembly or this may cause steering bind.*

6. Using the new Adjustable Lower Steering Mount, adjust the lower steering rod so that your tie rods are **as straight and level as possible**. If they are not, loosen the two bolts securing the Adjustable Lower Steering Mount to the frame to slide the mount forward and back,

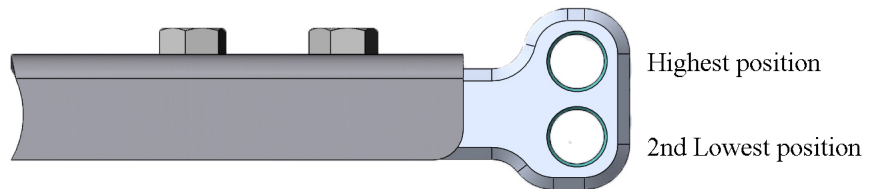
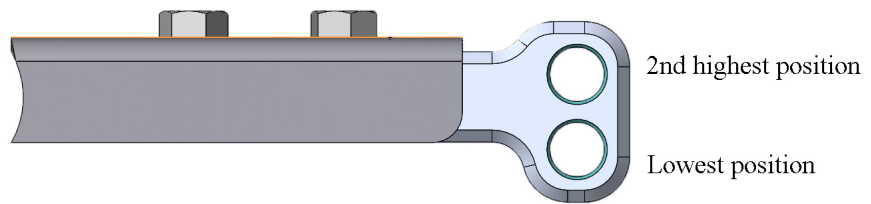

and move the rod end to the appropriate hole so that the tie rods become straight and level. The entire mount can be turned 180-degrees in its receptacle, allowing 4 different locations for the rod end (seen above). Once you've found the appropriate location for the lower steering mount, tighten all bolts & nuts, and install the cotter pin in the bottom of the steering shaft.

***Be sure to safety wire the two 5/16" bolts that secure the lower steering mount to the frame!***

7. Now that the steering shaft and yoke are aligned, tighten the 1/2-20 jam nut for the steering yoke.

### 3.2 Steering Wheel Mounting

All the necessary hardware to mount your steering wheel is included in your kart kit. Please take time to inspect each piece before you use it to make sure they are free from any defects.

1. The splined steering wheel hub is equipped with two different hole patterns to accommodate a variety of steering wheel patterns. Match the correct pattern to your steering wheel and install the three 1/4"-28 x 1 1/4" hex head bolts (with end drilled for safety pins) through the steering wheel first then through the hub.

*TIP: If you plan on utilizing a tachometer now may be a good time to mount your tach bracket if it mounts on the steering wheel.*

2. Now install one 1/4"-28 NLN (Nylon lock Nut) on each bolt and securely tighten. Was tight be sure to install the safety pins in the end of each bolt.
3. Install the 5/8" external snap ring over the splined end of the steering shaft and into the groove at the end of the splines.
4. Install the steering wheel that is already mounted to the splined steering wheel hub over the splines of the steering shaft. Be sure to position the steering wheel per the driver's comfort and in relation to the seat position.

*TIP: If you are utilizing a locking steering block make sure that you have installed the steering block locking collar and the locking pin's cable on the steering shaft before installing the steering wheel.*



### 3.3 Seat Mounting

Many racers do not realize the importance of seat location and how seat stress effects a chassis' performance. Because a kart is non-suspended, the chassis itself is the suspension in which it must act like a big spring. Anything you bolt to this spring in some way affects its performance. The seat is the largest and most rigid component that is bolted to the chassis and because it is bolted to the chassis with a large four-point pattern, it greatly affects the chassis flex. In-house testing has shown seats to affect chassis flex up to 10%. Combine the effects of chassis flex with the effects of the driver's body position to weight transfer, and the seat becomes a very important factor in winning races.

We're not trying to make you afraid of mounting your seat; we are trying to educate you about the importance of doing it correctly. If you will follow this simple procedure, you will find the job of mounting your seat much easier and rewarding.

Before you start mounting your seat you must first determine what position is best to start with for your driver and situation. All this takes is a little thought and common sense.

- 1. Left to Right Position.** Take into consideration the size of the driver, track configuration and track-condition. If you feel that you need high left side weight percentages then you want to mount the seat more to the left. On the contrary, if you feel that you need more side bite, then mount the seat more to the right for added weight transfer. One variable to take into consideration is the amount of weight you will be adding to the chassis. It is best to try and keep the amount of weight from left to right side of the seat as even and proportionate as possible.
- 2. Front to Rear Position.** The driver's build greatly effects the nose weight of the kart so take into consideration where your driver is carrying the bulk of his/her weight; high, low, or in the middle. Take this information into consideration with what percentages you want to end up with on the scales and determine how far forward or back you want to mount the seat.
- 3. Seat Height.** Consider the driver's build and your track information to determine how high to mount the seat. If you feel more weight transfer is needed for your situation then it's best to mount the seat a little higher. For less weight transfer, which is generally preferred, mount the seat in a low position but be sure to stay within the rules and safety limits.

**More Seat Mounting Tips.** If you have additional questions regarding where and how to mount your seat, you have plenty of options. Consult the PRC® Dealer whom you purchased the chassis from to get their recommendations. In addition, visit the Phantom® website, [www.phantomchassis.com](http://www.phantomchassis.com), to find instructional videos on seat mounting, chassis maintenance, and much more!

#### *How it's done:*

1. By now you should have a good idea what position you want to mount your seat. Start by adjusting the front seat slides out to an even amount and slightly tighten the 1/4-28 SHCS just enough to hold in place.

*TIP: If you do not have a partner helping you, use some sort of a "stiff knee" to hold up the back of the seat while you position the seat in the kart for measuring.*

2. Using the stiff knee or your partner, position the seat in the kart as you are intending to mount it. Inspect and measure the seat from all angles. Adjust the seat slides and the stiff knee until you have the seat positioned exactly as you are going to mount it.

*TIP: Be sure you have the rear seat height correct at this point and that the bottom of the seat is also positioned on a parallel plane with the bottom of the frame. To meet the 14" seat height rule, the top center back of the seat must measure a minimum of 8 3/8" off the top of the axle. This seat height measurement may very depending on what class you run and your sanctioning body or tracks rules, so check your rules before deciding on this. Also your axle position, tire circumference and air pressures will affect it as well when you are at the track.*

3. Once you have the seat in position, mark the three bottom holes with a marker or scribe. Drill the three marked holes with a 21/64<sup>th</sup> drill. Mount these three holes using the correct hardware supplied in the “kart kit.” Be sure to use (1) 5/16”-24 x 1 1/4” BHSC screw, (2) 5/16” SAE washers, (1) 5/16”-24 nylock nut and (1) rubber grommet for each mounting hole. Tighten each assembly just enough to slightly compress the rubber grommet.

*TIP: When marking your seat mounting holes do not forget to take into consideration the thickness of the rubber grommets. If you do not allow for this, you could raise or lower the seat position when you install the grommets.*

4. Check to make sure the seat is still in the correct position. Mount the left side seat strut on the left side nerf bar tube and tighten slightly so it can be adjusted as needed. Position the strut up to the seat in the mounting position with approximately 1/4” clearance between the strut and the seat. Check your rear seat height. Mark and drill the hole with a 21/64<sup>th</sup> drill. Mount and tighten with the same type hardware as the front mounts.

*TIP: Depending upon the style and size of seat you use, you may need to slightly bend the mounting area of the seat struts and seat slides to match the seat itself. We take great efforts to manufacture these parts to prevent this but it is impossible to make them so they will match every seat perfectly. The rubber grommet should compress evenly and not just on one side.*

5. Repeat this same procedure for the right side strut.

*TIP: All holes should line up without having to put the seat or chassis in a bind. If you have to manipulate the seat over 1/4” to install the bolt, you should drill another hole.*

6. Now that all points of the seat are mounted, securely tighten ALL fasteners EXCEPT the left front seat slide 1/4-28 SHCS bolt and the right front seat slide bar clamp. With them loose, twist the front of the seat to ensure the seat is not in a bind. If the seat appears to be in a bind, remount the seat. If not, securely tighten the seat slides.

*TIP: You should periodically check your seat to make sure all mounting points are secure and that the seat is not in a bind.*

### 3.4 Body Work Mounting

Much like the seat, bodywork can also affect the performance of your chassis. Properly mounting the body is important to achieving maximum performance from your kart. In addition, it is highly recommend that only authentic Phantom<sup>®</sup> bodywork is used. PRC<sup>®</sup> chassis’ are designed exclusively with Phantom<sup>®</sup> bodywork.

***TIP: Before mounting your body, be sure that both the toe and camber settings are close to what you expect to use!***

1. Mount a set of tires on the kart that are relative to the sizes you are expecting to run. Stagger, compound and air pressures are not important at this time; we simply need something to line the body to.
2. Put the kart on a flat surface and place the nosepiece over the front bumper. Place a spacer under the bottom of the nose to bring the nose up level with the bottom of the kart (A 2-by-4 works well).
3. Position the nose so it is centered over the wheels and so the wheel-wells are centered with the tires. Drill and mount the nose at the front.
4. Position side panels/pods to fit the nerf bars and align with the nose. Be sure to check that nerf bar widths are within technical requirements. These requirements can be found in your sanctioning body’s tech manual.

*TIP: If you are mounting a body that the sides connect to the nose, you may have to trim the back edge of the nose to get a perfect match between the sides and the nose.*

5. After you make sure everything is properly positioned and trimmed, fasten the sides to the nose, and then to the nerf bars (be sure to follow this order). Three fasteners between the nose and the side panels on each side are sufficient. Putting too many fasteners will restrict chassis flex.
6. If you are utilizing a driver's bubble and bracket now is the time to install them. If you did not mount your bubble bracket when you were assembling your steering earlier then you need to mount it now. Install the bubble bracket to the steering column with the supplied 5/16"-24 x 2 1/4" hex bolt. Then, mount the driver bubble (fairing) to the bracket in a manner that it does not restrict the driver's vision or ability to exit the kart.  
*TIP: When mounting your driver's bubble make sure you check your rule book for mounting specs. Normally, the bubble must be 3" from the steering wheel for hand clearance and 6" from any bodywork.*
7. Take time to go back over the complete body and do any trimming or sanding to make your job complete. Also take time to check behind yourself to make sure all fasteners are secure and free of potential safety problems. Use your best discretion with any safety concerns because the final decision is yours.

### *Using 1/4 -Turn Fasteners ("Dzus" style)*

1. Identify the mounting brackets on the nerf bars and the front bumper. Insert the rivets with the long end facing away from the bracket. Place the spring with the open end facing the bracket and rivets. Use .250 spring for the front bumper brackets, .300 for the nerf bar brackets.
2. Drill a hole for the 1/4 turn fastener in your bodywork. Insert the button and use the plastic washer to secure the fastener to the bodywork. To do so, place the washer on the backside of the bodywork, securing the button from falling out of the body.
3. Use an 3/16" Allen wrench to lock the fastener to the spring.
4. When changing bodywork, just unlock the fastener from the spring and remove the sides or nose.



### *3.5 Other Hardware Mounting*

Now it's time to mount any other hardware that you intend to have on the kart during competition. This will include things such as motor, drive train, fuel tank, oil catch can, tach, etc... Anything you bolt to the kart will affect the weigh-out, so you need to get them all on at this time. There are other publications that will help you with this step but the most important thing to remember is **safety first**. Be sure to check behind your work.  
**Note: Please see enclosed Setup Sheet for numbers to give you a starting point for weighing out your kart.**

## 4.0 DEUCE™ SETUP INFORMATION

### 4.1 Deuce™ Caster Information

#### *Caster Block Design: Two Ways to Set Your Caster*

Your Phantom® chassis incorporates a **caster block design** that allows you to adjust the caster and lead on both sides of the chassis. Each caster block is marked on the top to allow you to infinitely adjust your caster setting. Deuce™ caster blocks are designed using only one pin, so the caster blocks are ready to adjust if need be. To do so, rotate the caster block on the pin to adjust the caster. This gives you the ability to set your caster to any degree you desire. Please note, the caster has been pre-set on your Deuce™ chassis to 10° on the RF and 7° on the LF. This is the recommended caster setting for the Deuce™ chassis.

Please note that both the right front and left front of the Deuce™ have adjustable lead. You have the choice of two different lead settings. This lead difference causes the need to have two different centerline marks on the frame plate. Be sure to use the correct centerline mark for the lead setting you are using.

#### *What to expect from changing caster*

The intent of these blocks is to tune the feel of the kart to compliment the driving style of the driver. Please DO NOT commonly change these blocks in the middle of a race day to accommodate track conditions. The major difference you will see when you change caster is in the drivability of the kart. Lower caster causes the kart's steering to have *much less resistance* and may cause less experienced drivers to become darty or jerky. For this and other occasions, you may find that using a “non-recommended” caster may work to your advantage.

### 4.2 Deuce™ Camber Information

If you are not accustomed to the “reverse yoke” design or the camber adjustments of the Deuce™ please take a few minutes to look over Diagram 4.2 and notice how it all works. The better you understand your chassis, the better it will perform for you.

The Deuce™ allows the simplest camber adjustment of any chassis on the market today. You do not need to take the spindles off or the kingpin bolts out... you adjust the camber with the kart on the scales and the driver in the seat. Notice in Diagram 4.2 that the kart has an inner and an outer jam nut on the top ball joint. By adjusting these nuts in the direction that is noted in the diagram at the top the page you can adjust your camber accordingly.

Through testing, we have found that we can achieve better results out of adjusting camber than adjusting caster. From there you must take driver feedback, air pressure gains and the overall speed of the kart into consideration when adjusting your camber. Each driver will find a particular camber setting that will suit his/her driving style the best. No one can do it for you or tell you what will work the best for you. That's up to you.

Please note that you should only compensate for one condition. Do not add up several lines to come up with a major change. Also note that these are just recommendations for a starting point. If you find something that works better for you in your situation, please use those settings.

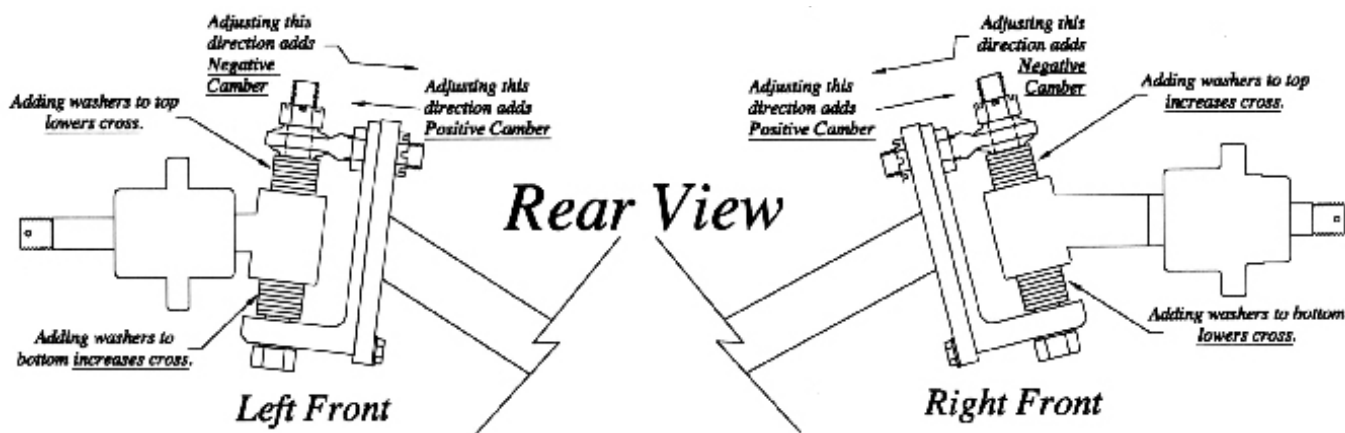

DIAGRAM 4.2 CAMBER SETUP

### Recommended Camber Settings for the Deuce™

Track Configuration	Left Front	Right Front
Flat Dirt Track	+0 to +.25	-2.75 to -3.50
Banked Dirt Track	+.25 to +.50	-3.00 to -3.75
Flat Asphalt Track	+.25 to +.50	-3.00 to -3.75
Banked Asphalt Track	+.5 to +1	-3.25 to -4.00
<i>If your track is (Compensate for only one)</i>		
Hard & Dry	Reduce -.5	Increase +.25
Damp & Tacky	Increase +.5	Reduce -.25
Small & Tight	Increase +.5	Increase +.5
Large & Sweeping	Reduce -.5	Reduce -.25

These settings are actual camber as checked with a camber gauge! **Be sure to recheck your toe after making a major camber adjustment!**

DIAGRAM 4.3

### 4.3 Deuce™ Adjustable Lead

The Phantom® Deuce™ is equipped with a feature that allows the racer to adjust the lead in the chassis to fit his/her driving style. The left front and right front caster block utilizes one dowel pin. The dowel pin is not to be removed from the block. The Deuce™ is designed with lead adjustment on both the LF and RF. Reducing the lead will often times make the front end of the kart more responsive. Each racer will need to experiment with the different settings to see which one better suits his/her driving style and track conditions. Be sure to check your toe and camber settings after you change the lead!

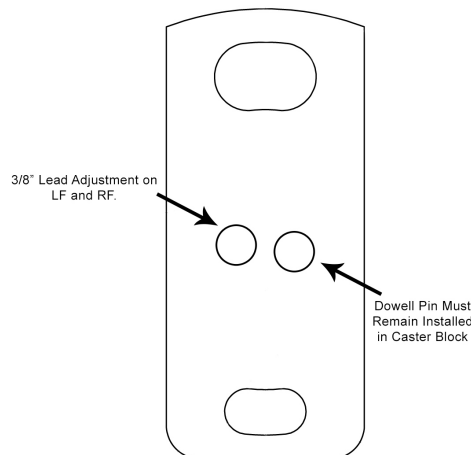

## 4.4 Rear Cassette “Quick Release” Pins

Your Deuce™ chassis is designed with two quick release pins in each of the rear cassettes. These pins allow you even more adjustability than before. However, these pins are not to be used for fine tuning purposes, as these pins will significantly change the handling of your chassis and we recommend not changing them on a regular basis.

Both rear cassettes have been designed so that you may use the pins to increase or decrease your chassis ride height, rake, and/or cross weight.

In order to fully utilize this new feature, please understand that this adjustment is meant to only be used when you are setting a baseline setup for your chassis. These changes will drastically influence the amount of cross weight the chassis will have.

There are two main reasons you may want to change the axle height position. One is ground clearance. For rougher tracks, you will raise the kart, lower the axle, to get enough ground clearance to miss the bumps. While on smooth tracks you can lower the kart, raise the axle, to reduce the weight transfer. That brings us to the second reason, weight transfer. As you increase the ground clearance of a chassis, you also increase the vertical CG, which creates more lateral weight transfer. Many racers use this as a tuning tool to increase or decrease side bite. To change ride height, move both cassettes equally.

The amount of cross weight that will change is dependent on several factors. These factors include the seat positioning, driver size, stagger, and your wheel hub settings. You can expect that with each incremental change, 3%-5% of cross weight will be changed. We currently have 6 different settings for the Deuce™ chassis ride height. Each line on your cassette bottom indicates .100” increments. Stock position is indicated by the arrow, shown in Diagram 4.4. We recommend that if you do choose to make this adjustment, that you only move one increment at a time. To change cross, move only one cassette at a time.

*Please keep in mind, this is not a fine tuning adjustment and should only be used when significant changes are desired.*

## 4.5 Weigh-Out Information

### **Remember**

When you are weighing out your kart, have everything as you intend to race. Meaning, set your stagger, air pressure, type of tires and etc. just like you are going to head out onto the track. Changing these variables after you weigh-out your kart will cause you to become confused when you start to make changes at the track. If you know how the kart is weighed in a certain condition, you can make more educated decisions.

### **Please Note**

Scaling your chassis is one of the most important steps in having a successful chassis setup. Spending a little extra time scaling your chassis will save you time getting around the track!

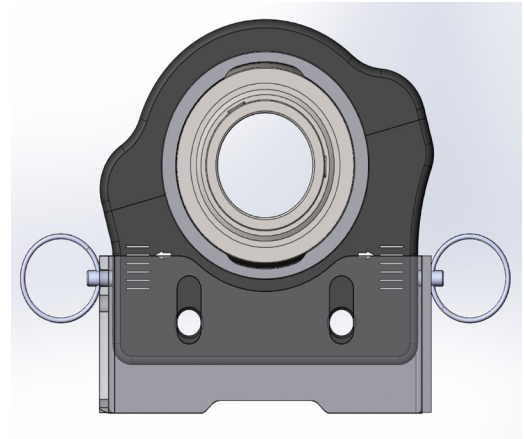

**DIAGRAM 4.4**

It's VERY important that you have a good set of scales and have them set-up properly. Throwing a set of bathroom scales onto a concrete floor is better than nothing, but not very accurate. If your scales are not properly level, your final numbers will not be accurate either. Consider this... one spindle washer is 1/16" thick, so for every .060 that your scales are out of level, that equals one spindle washer.

Many racers experience the cross weight of a kart changing from one run to the next or even from one time on the scales to the next. The leading factor to this is tires and in what position they come in contact with the scales. Kart tires are bias-ply, which results in excessive run-out (high and low places). Allowing the tires to sit on the scales at different rotations will result in the cross weight varying up to two percent. Even though this has nothing to do with the chassis, the chassis is always the first blamed. One good habit that will correct this problem is to always place the valve stems of the wheels in the same location when you weigh-out your chassis.

Now you're ready to start burning the track up! **Please take time to go over your work and make sure everything is safe.** Check all fasteners and cotter pins to make sure they are tight and in place. A little time now could not only save you from falling out of a race, it could save you or your driver from injury.

*Please remember, racing is a dangerous sport. Wiggins Kart Shop, Inc. and/or Phantom Racing Chassis® is not liable for injuries that may occur while using any product/s we sell and/or manufacture. The final decision of the safety and use of any product is the responsibility of the user. The user accepts all responsibility. All products that are sold by Wiggins Kart Shop, Inc. and /or Phantom Racing Chassis® are intended for professional racing ONLY!*

### 4.6 Recommended Starting Setups

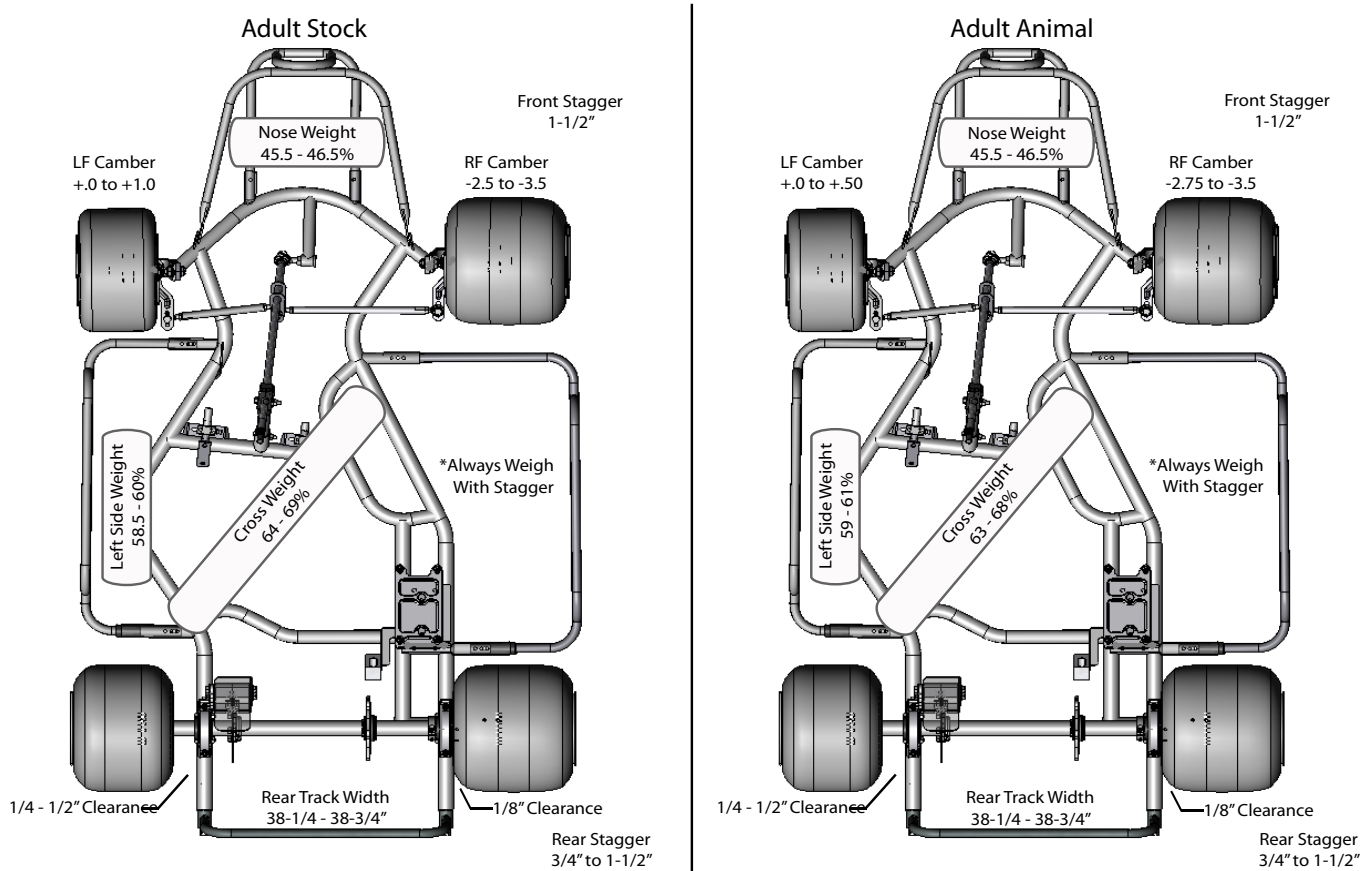

## 5.0 BEARING MAINTENANCE

### 5.1 PRC® Performance Rear Axle Bearings

Your Phantom® chassis is either equipped with PRC® steel bearings or PRC® Ceramic bearings. Please take a few minutes to read and follow this section in order to get the maximum life and performance out of these bearings.

It is important that you use the correct type of oil to achieve maximum performance from your bearings. Along with your chassis, you received a 2 oz bottle of PRC® Performance oil. We have found this oil to perform very well under racing conditions. This 2 oz bottle should last for a few weeks of racing and additional bottles can be purchased at your Phantom® dealer. PRC® Performance oil is also available in 8 oz bottles for both the steel and ceramic bearings. Be sure to use the correct oil in your bearings.

Your bearings are pre-lubed at the factory, so there is no need to add additional lubrication prior to use. After you put your chassis into use, you should lube the bearings each week. The amount of oil needed each week will depend upon the amount of contaminants your bearings run in. If you run on a dusty dirt track you will want to use enough oil to flush the dust and dirt out of the seals before you leave the track. But, if you run an asphalt track, you will only need to add a few drops each week to replenish the oil that was wasted through normal use. Be sure to remove any excess oil that may accumulate around the outside of the bearing. If this excess oil is left on the outside it will cause dust, dirt, and other contaminants to stick to the outside of the bearing. If left, such contaminants will work their way into the bearing and cause the bearing to fail.

In order to lube your bearings, you will need to remove only one side of the factory installed exterior metal shield and interior rubber seal. Next, use mineral spirits to clean all of the contaminants out of the inside of the bearings. Then, use denatured alcohol to remove the residue left from the mineral spirits. Now, place 3-5 drops of PRC bearing oil into the bearing. **DO NOT** over lube the bearing.

After removing the factory outer shield and inner seal, you will notice the outer metal shield will not fit back into the bearing correctly. Unfortunately, after removal they will become deformed and should not be forced back into place. Instead, simply re-install the inner seal, which can be repeatedly removed and replaced back in the bearing to allow proper protection from contaminants.

**PLEASE NOTE:** When you wash your chassis, **DO NOT use high-pressure water or air around the bearings!** Even the pressure of a garden hose can force water and grit past the seals and inside the bearings.

Once this grit is inside the bearings it will cause the bearing to fail. Simply wipe the grit from the outside of the bearings with a rag and flush the bearings out with the oil listed above. This will clean the seals from the inside out and greatly prolong bearing life.

#### ***Tightness or Tight Spots***

Should your axle assembly suddenly become tight or have a tight spot in the rotation, chances are the bearings have somehow gotten in a bind. The fix is simple. Simply loosen one of the bearings from the axle. To do this, loosen the setscrews that lock the inner race to the axle and loosen any axle collars that may be used. Spin the axle and see if the tight spot or tightness is gone. If it is, retighten the setscrews and axle collars and you're ready to go. If this does not remedy the problem, the bearings may be bound to the cassette.

**DIAGRAM 5.1**

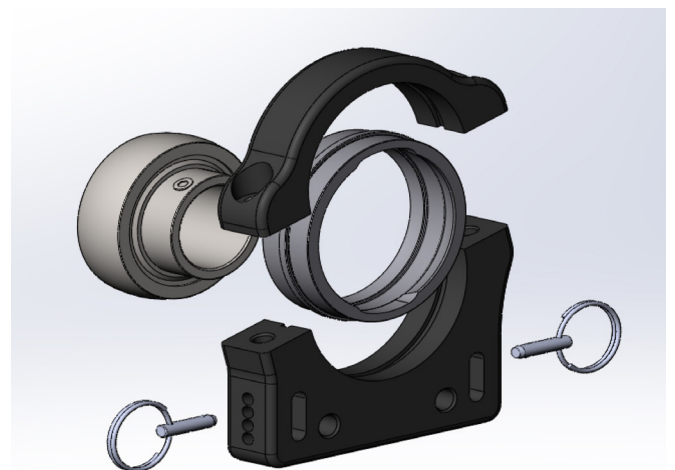



If that is the case, try tapping the cassette firmly with a rubber hammer while spinning the axle.

Should you remove your bearings from the cassettes, refer to Diagram 5.1 to ensure you properly assemble them again.

Our new rear cassette utilizes a split design that allows our PRC® performance bearings to be securely clamped within the top and bottom cassette halves. In addition, the PRC® performance bearing is placed inside a bearing insert, that allows the fit and tolerance of the bearing within the cassette to be much more precise than ever before.

*Please Note: We highly recommend that as part of your weekly maintenance you check the tightness of the cassette cap bolts and the bolts that connect the cassette to the frame.*

*Recommended Torque Specs: Cassette Cap Bolts : 175 in-lbs & Cassette Frame Bolts: 200 in-lbs.*

## **5.2 Front Hub Bearings**

Your front hub bearings are for the most part maintenance free. These bearings are grease filled and sealed to prevent dirt from entering the bearing under normal conditions. It is important that you properly clean around these bearings in order for these seals to work properly. Any dirt or grit that may accumulate around the outside of the bearing should be wiped away with a rag to prevent the grit from eventually damaging the seal. DO NOT use high-pressure water or solvents to remove this grit. The high pressure will force the grit past the seal and into the bearing.

After the hub bearings have been run for some time and start giving problems, it's best to just replace the complete bearing. Removing the factory seals to clean and re-lubricate the bearings is sometime effective but often the factory seals are damaged.

## **5.3 Kingpin Bearings**

Your kingpin bearings for the most part are maintenance free. These bearings are grease filled and sealed to prevent dirt from entering the bearing under normal conditions. It is important that you clean around these bearings for the bearings to work properly. Any dirt or grit that may accumulate around the outside of the bearing should be wiped away with a rag. You can lubricate the bearings with some light grease or WD-40 and this will help prevent any friction with the kingpin bolt and help to keep your steering free. If the bearings become worn or feel tight, then it is time to replace them.

These bearings are under a load which can cause them to fail. Since these bearings control your front geometry, it is a good idea to replace the bearings a couple times per year.

PLEASE NOTE... these bearings have a spacer which aligns them inside the spindle barrel. Make sure that when you replace the bearings, you insert them back into the spindle in the same way that they were originally.

## 6.0 BRAKE INSPECTION AND MAINTENANCE

When it comes to your driver's safety, there is nothing more important than your brake system. You should inspect the complete brake system each week for things such as fluid level, pad wear, pad gap, fluid leaks, loose fasteners, and etc. Anything that may look suspicious or unsafe in the brake system should be addressed and fixed before the kart is put back on the track. *Note: Brake bracket tightness should be checked regularly. Torque Specs are 175 in-lbs.*

### 6.1 Bleeding Instructions

1. Be sure all hydraulic connections are secure. Never use Teflon tape to seal the fittings in the castings. An appropriate Teflon paste like that used from the manufacturer is recommended. The high-pressure tubing should be inserted completely into the cap and ferrule. From finger tight, the fitting cap should be tightened two turns. This should leave a gap of about .050" between the cap and the hex part of the fitting body.
2. Remove the filler plug from the master cylinder top and fill reservoir with *DOT-5 silicone brake fluid only!* Stroke the master cylinder lever arm a full stroke and open the bleed screws on the caliper for about two seconds then close. Allow the master cylinder arm to return to the rest position and wait approximately ten seconds to allow for the fluid in the reservoir to transfer into the bore of the master cylinder. Repeat the process of stroking the master cylinder again, open and close the bleed screws the same as before wait again. Continue this procedure until a firmer pedal is realized (depending on the length of line used, this will probably be four to six times)
3. After the pedal has become reasonably firm, take shorter strokes of the master cylinder with the bleed screws open so as to allow only a short spurt of brake fluid to escape. For the finishing process the brake pedal should be held down firmly as possible before opening the bleed screws to purge as much air with the escape of fluid as possible.
4. Check all hydraulic connections for any possible fluid leaks.

## 7.0 ADDING BALLAST WEIGHT (LEAD)

Another very important safety feature that many racers often-over look is how, where and how much ballast weight they are adding to the kart. Remember to also use a **Minimum 5/16" Grade 8 bolts with jam nut and safety pin when applying ballast weight!**

It is also very important that you *use a rubber grommet between the ballast weight and the seat*. This grommet will prevent the seat from being damaged when you tighten the ballast weight. When placing your ballast weight on the chassis, we recommend trying to keep the weight placement even from left to right side of the seat. This is not always going to be an easy task, but we do recommend trying to locate your weight as evenly as possible.

## 8.0 PAINT CARE AND CLEANING

Your new Phantom® chassis is coated with a state of the art powder coating process to ensure your chassis will stay looking great for years to come. In order to get the maximum life and appearance out of your powder coated chassis, it's important to properly maintain your chassis surface. Just like any painted surface, it's important that you apply a coat of wax to protect the surface from scratching and fading. Depending on how often you race your kart, you should wax your chassis and it's components every 1 to 4 months. If you race your kart more often, you should wax it more often.

Be sure to wash your chassis between races with water and a mild detergent such as any of the popular car washing detergents. **It is not recommended to wash your chassis with high pressure.** High pressure can remove the powder coat and force water and dirt into all of the bearings on your kart. A gentle garden hose and some elbow grease will do just fine. **Do not use any high strength detergents or solvents to clean your chassis.** They will damage your powder coat by causing it to fade, crack and may even remove the powder coat all together. Using such detergents and solvents will also fade and/or remove the anodizing and oxidizing of the components.

*It is recommended to remove your axle and front hubs prior to cleaning, so that water cannot penetrate your bearings.*

After you have washed your kart, be sure to **apply a little surface oil to the black oxide parts** such as the steering shaft, and pedal rods. WD-40, LPS, etc. work fine. These parts may begin to rust if they are not kept lubricated.

Most electronics do not like to be washed. Unless your instruments such as your tachometer and lap timer are waterproof, you may want to remove them prior to washing. *(Just a suggestion)*

## 9.0 BENT OR BROKEN PARTS

If you race, you're going to get into wrecks and you're going to damage some parts. Before you repair those parts yourself, consider the safety factor. **Phantom Racing Chassis® does not recommend repairing any parts that are damaged.** Each component on your kart is there for a reason and if that component does not work properly, it may be unsafe. Example, The nerf bars are there to act as a crush zone that will absorb energy when the kart is hit in the side. Once that bar has been crushed, it has done its job and needs to be replaced. If you straighten that bar and reuse it, it will not provide the same protection for the next hit. Please consider the safety of your driver before you put him/her back into competition with damaged parts. **After all, the final decision to the safety of your chassis rests on you every time your kart goes on the track!**

## 10.0 PERFORMANCE

### *Recommended Tire and Wheel Size*

Due to the fact that our chassis are used all over the United States, from the Saturday night bullrings, to the weeklong Grand National events, we simply cannot predict what type of situations you will encounter. Different track configurations and track surfaces will cause you to run the spectrum on tire sizes and compounds. The best advice we can give you on choosing the tires you should start with, is to contact some of the racers that normally run at the track you are going to. Also, you should definitely contact the local Authorized Phantom Dealer that services that track for their recommendation. For more information about tires and how they work, check out the *Top Secret Video Club™*. There are two videos dedicated to kart tires. (Tires & Rims™ Part #116004 and Tires Vol. 2™ Part #116006.)

Below are some recommended wheel widths to start with on your new Phantom® chassis. Once you have raced your chassis a few times, you may find that using a different size may work better for you, so do not be afraid to try.

#### **Dirt Oval Tracks**

LF – 6 ½”	RF – 10”
LR – 8 ½”	RR – 10”

## 11.0 SERIAL NUMBERS

It's important to locate and record your serial number as soon as possible. Please write it on the front of this manual as well as on your registration card. When you send us the registration card, we will log all of your information into our system so that it is on file. We will also keep your number on file for you in case you lose it or the serial number tag becomes lost. You can register a new or used chassis. If you can't find your registration card, you can register over the telephone.

Phantom serial numbers are a six digit number. The Deuce™ chassis has a black plate riveted to the frame with the serial number etched on this plate. The serial number is located in front of the right side nerf bar, on the main frame rail. PRC® serial numbers are secured to the frame using specialized rivets. If you have any problems locating the serial number, please contact us.





*Phantom Racing Chassis*

## Gear Ratio Chart

*Front Sprocket*

	9	10	11	12	13	14	15	16	17	18	19	20	21	22	23
<b>53</b>	5.89	5.30	4.82	4.42	4.08	3.79	3.53	3.31	3.12	2.94	2.79	2.65	2.52	2.41	2.30
<b>54</b>	6.00	5.40	4.91	4.50	4.15	3.86	3.60	3.38	3.18	3.00	2.84	2.70	2.57	2.45	2.35
<b>55</b>	6.11	5.50	5.00	4.58	4.23	3.93	3.67	3.44	3.24	3.06	2.89	2.75	2.62	2.50	2.39
<b>56</b>	6.22	5.60	5.09	4.67	4.31	4.00	3.73	3.50	3.29	3.11	2.95	2.80	2.67	2.55	2.43
<b>57</b>	6.33	5.70	5.18	4.75	4.38	4.07	3.80	3.56	3.35	3.17	3.00	2.85	2.71	2.59	2.48
<b>58</b>	6.44	5.80	5.27	4.83	4.46	4.14	3.87	3.63	3.41	3.22	3.05	2.90	2.76	2.64	2.52
<b>59</b>	6.56	5.90	5.36	4.92	4.54	4.21	3.93	3.69	3.47	3.28	3.11	2.95	2.81	2.68	2.57
<b>60</b>	6.67	6.00	5.45	5.00	4.62	4.29	4.00	3.75	3.53	3.33	3.16	3.00	2.86	2.73	2.61
<b>61</b>	6.78	6.10	5.55	5.08	4.69	4.36	4.07	3.81	3.59	3.39	3.21	3.05	2.90	2.77	2.65
<b>62</b>	6.89	6.20	5.64	5.17	4.77	4.43	4.13	3.88	3.65	3.44	3.26	3.10	2.95	2.82	2.70
<b>63</b>	7.00	6.30	5.73	5.25	4.85	4.50	4.20	3.94	3.71	3.50	3.32	3.15	3.00	2.86	2.74
<b>64</b>	7.11	6.40	5.82	5.33	4.92	4.57	4.27	4.00	3.76	3.56	3.37	3.20	3.05	2.91	2.78
<b>65</b>	7.22	6.50	5.91	5.42	5.00	4.64	4.33	4.06	3.82	3.61	3.42	3.25	3.10	2.95	2.83
<b>66</b>	7.33	6.60	6.00	5.50	5.08	4.71	4.40	4.13	3.88	3.67	3.47	3.30	3.14	3.00	2.87
<b>67</b>	7.44	6.70	6.09	5.58	5.15	4.79	4.47	4.19	3.94	3.72	3.53	3.35	3.19	3.05	2.91
<b>68</b>	7.56	6.80	6.18	5.67	5.23	4.86	4.53	4.25	4.00	3.78	3.58	3.40	3.24	3.09	2.96
<b>69</b>	7.67	6.90	6.27	5.75	5.31	4.93	4.60	4.31	4.06	3.83	3.63	3.45	3.29	3.14	3.00
<b>70</b>	7.78	7.00	6.36	5.83	5.38	5.00	4.67	4.38	4.12	3.89	3.68	3.50	3.33	3.18	3.04
<b>71</b>	7.89	7.10	6.45	5.92	5.46	5.07	4.73	4.44	4.18	3.94	3.74	3.55	3.38	3.23	3.09
<b>72</b>	8.00	7.20	6.55	6.00	5.54	5.14	4.80	4.50	4.24	4.00	3.79	3.60	3.43	3.27	3.13
<b>73</b>	8.11	7.30	6.64	6.08	5.62	5.21	4.87	4.56	4.29	4.06	3.84	3.65	3.48	3.32	3.17
<b>74</b>	8.22	7.40	6.73	6.17	5.69	5.29	4.93	4.63	4.35	4.11	3.89	3.70	3.52	3.36	3.22
<b>75</b>	8.33	7.50	6.82	6.25	5.77	5.36	5.00	4.69	4.41	4.17	3.95	3.75	3.57	3.41	3.26
<b>76</b>	8.44	7.60	6.91	6.33	5.85	5.43	5.07	4.75	4.47	4.22	4.00	3.80	3.62	3.45	3.30
<b>77</b>	8.56	7.70	7.00	6.42	5.92	5.50	5.13	4.81	4.53	4.28	4.05	3.85	3.67	3.50	3.35
<b>78</b>	8.67	7.80	7.09	6.50	6.00	5.57	5.20	4.88	4.59	4.33	4.11	3.90	3.71	3.55	3.39
<b>79</b>	8.78	7.90	7.18	6.58	6.08	5.64	5.27	4.94	4.65	4.39	4.16	3.95	3.76	3.59	3.43
<b>80</b>	8.89	8.00	7.27	6.67	6.15	5.71	5.33	5.00	4.71	4.44	4.21	4.00	3.81	3.64	3.46
<b>81</b>	9.00	8.10	7.36	6.75	6.23	5.79	5.40	5.06	4.76	4.50	4.26	4.05	3.86	3.68	3.52
<b>82</b>	9.11	8.20	7.45	6.83	6.31	5.86	5.47	5.13	4.82	4.56	4.32	4.10	3.90	3.73	3.57
<b>83</b>	9.22	8.30	7.55	6.92	6.38	5.93	5.53	5.19	4.88	4.61	4.37	4.15	3.95	3.77	3.61
<b>84</b>	9.33	8.40	7.64	7.00	6.46	6.00	5.60	5.25	4.94	4.67	4.42	4.20	4.00	3.82	3.65
<b>85</b>	9.44	8.50	7.73	7.08	6.54	6.07	5.67	5.31	5.00	4.72	4.47	4.25	4.05	3.86	3.70
<b>86</b>	9.56	8.60	7.82	7.17	6.62	6.14	5.73	5.38	5.06	4.78	4.53	4.30	4.10	3.91	3.74
<b>87</b>	9.67	8.70	7.91	7.25	6.69	6.21	5.80	5.44	5.12	4.83	4.58	4.35	4.14	3.95	3.78
<b>88</b>	9.78	8.80	8.00	7.33	6.77	6.29	5.87	5.50	5.18	4.89	4.63	4.40	4.19	4.00	3.83
<b>89</b>	9.89	8.90	8.09	7.42	6.85	6.36	5.93	5.56	5.24	4.94	4.68	4.45	4.24	4.05	3.87
<b>90</b>	10.00	9.00	8.18	7.50	6.92	6.43	6.00	5.63	5.29	5.00	4.74	4.50	4.29	4.09	3.91
<b>91</b>	10.11	9.10	8.27	7.58	7.00	6.50	6.07	5.69	5.35	5.06	4.79	4.55	4.33	4.14	3.96
<b>92</b>	10.22	9.20	8.36	7.67	7.08	6.57	6.13	5.75	5.41	5.11	4.84	4.60	4.38	4.18	4.00
<b>93</b>	10.33	9.30	8.45	7.75	7.15	6.64	6.20	5.81	5.47	5.17	4.89	4.65	4.43	4.23	4.04
<b>94</b>	10.44	9.40	8.55	7.83	7.23	6.71	6.27	5.88	5.53	5.22	4.95	4.70	4.48	4.27	4.09
<b>95</b>	10.56	9.50	8.64	7.92	7.31	6.79	6.33	5.94	5.59	5.28	5.00	4.75	4.52	4.32	4.13
<b>96</b>	10.67	9.60	8.73	8.00	7.38	6.86	6.40	6.00	5.65	5.33	5.05	4.80	4.57	4.36	4.17
<b>97</b>	10.78	9.70	8.82	8.08	7.46	6.93	6.47	6.06	5.71	5.39	5.11	4.85	4.62	4.41	4.22
<b>98</b>	10.89	9.80	8.91	8.17	7.54	7.00	6.53	6.13	5.76	5.44	5.16	4.90	4.67	4.45	4.26
<b>99</b>	11.00	9.90	9.00	8.25	7.62	7.07	6.60	6.19	5.82	5.50	5.21	4.95	4.71	4.50	4.30
<b>100</b>	11.11	10.00	9.09	8.33	7.69	7.14	6.67	6.25	5.88	5.56	5.26	5.00	4.76	4.55	4.35

Rear Sprocket

For specific gearing questions, concerns, etc. it is best to contact your engine builder. They will be able to suggest the best starting gear, ratio, or appropriate RPM's for the track you plan to attend.

# *NOTES*

# *NOTES*





# WIGGINS KART SHOP, INC.

4010 HWY 152 WEST • CHINA GROVE, NC 28023

TEL: (704) 855-3165 • FAX: (704) 857-5819

[WWW.PHANTOMCHASSIS.COM](http://WWW.PHANTOMCHASSIS.COM) • [PHANTOMRACINGCHASSIS@GMAIL.COM](mailto:PHANTOMRACINGCHASSIS@GMAIL.COM)

version JS-20181002