



Phantom Racing Chassis

Phenom™

Owner's Manual

Your Serial Number:

Please have this number ready when/if you call for setup or tech help. Thanks!

***Please read and understand this manual
before assembling or using this product.***

Remember, racing is a dangerous sport. Wiggins Kart Shop, Inc. and/or Phantom Racing Chassis® is not liable for injuries that may occur while using any products we sell and/or manufacture. The final decision of the safety and use of any product is the responsibility of the user. The user accepts all responsibilities. All products that are sold by Wiggins Kart Shop, Inc. and/or Phantom Racing Chassis® are intended for professional racing only.

TABLE OF CONTENTS

INTRODUCTION

1.0 INSPECTION OF NEW CHASSIS	4
2.0 CUSTOMER CHECKLIST	5
2.1 <i>Phenom Standard Package</i>	
2.2 <i>Phenom Champion's Edition Package</i>	
2.3 <i>Phenom Asphalt Upgrade Champion's Edition Package</i>	
3.0 BASIC OVERVIEW OF ASSEMBLY	7
3.1 <i>Steering Support</i>	
3.2 <i>Seat Mounting</i>	
3.3 <i>Steering Wheel Mounting</i>	
3.4 <i>Setting Toe</i>	
3.4.1 <i>With Accutoe Pro System</i>	
3.4.2 <i>With Accutoe Pro Expansion Kit Option</i>	
3.4.3 <i>With Original Accutoe System</i>	
3.5 <i>Body Work Mounting</i>	
3.6 <i>Other Hardware Mounting</i>	
4.0 PHENOM SETUP INFORMATION	15
4.1 <i>Phenom Caster Information</i>	
4.2 <i>Phenom Camber Information</i>	
4.3 <i>Phenom RF Adjustable Lead</i>	
4.4 <i>Weight Out Information</i>	
4.5 <i>Spindle Options</i>	
5.0 BEARING MAINTENANCE	19
5.1 <i>PRC Lubable Rear Axle Bearings</i>	
5.2 <i>Kingpin Bearing</i>	
5.3 <i>Standard Rear Axle Bearing</i>	
5.4 <i>Front Bearing</i>	
6.0 BRAKE INSPECTION AND MAINTENANCE	21
6.1 <i>Bleeding Instructions</i>	
6.2 <i>Caliper Rebuild Instructions</i>	
6.3 <i>Master Cylinder Rebuild Instructions</i>	
7.0 REAR AXLE POSITIONS	23
8.0 ADDING BALLAST WEIGHT (LEAD).....	24
9.0 ADJUSTABLE CASSETTE INSTALLATION AND USE	24
10.0 PAINT CARE AND CLEANING	25
11.0 BENT OR BROKEN PARTS	25
12.0 PERFORMANCE.....	25

Recommended Tire and Wheel Sizes

13.0 SERIAL NUMBERS 26

RESOURCES:

Phenom Set Up Sheet

Gear Ratio Chart

Phantom Kart Note Pad Sample

Introduction



Phantom Racing Chassis

Congratulations on the purchase of your new Phantom® Racing Chassis. We pride ourselves in providing our customers with the necessary information to allow them to run up front. This owner’s manual is another step in the learning process and hopefully you will find this manual informative.

This manual contains valuable information on the inspection, assembly, set up, and maintenance of your new chassis. Please do not take sections of this manual for granted, all are equally important. Whether you are a new racer or a seasoned veteran, this manual can help you. Thanks again for your patronage and most of all... Good Luck!

DISCLAIMER: Please remember, racing is a dangerous sport. Wiggins Kart Shop, Inc. and/or Phantom Racing Chassis® is not liable for injuries that may occur while using any products we sell and/or manufacture. The final decision of the safety and use of any product is the responsibility of the user. The user accepts all responsibilities.

This booklet and all information contained therein are copyright of Wiggins Kart Shop, Inc. and Phantom Racing Chassis®. Any republication of this document without written consent from Wiggins Kart Shop, Inc. and Phantom Racing Chassis® is prohibited.

All Logos and Item Names used by Wiggins Kart Shop, Inc. and Phantom Racing Chassis® are under Trademark and/or registered Trademarks of Wiggins Kart Shop, Inc. and/or Phantom Racing Chassis. Any use of these Logos or Item names without written consent from Wiggins Kart Shop, Inc. and Phantom Racing Chassis® is Prohibited.

Warranty: Wiggins Kart Shop, Inc. and/or Phantom Racing Chassis known henceforth as “seller” MAKES NO WARRANTY OF ANY KIND, EXPRESS OR IMPLIED, except that the goods sold under this agreement shall be of the standard quality of seller, and buyer assumes all risk and liability resulting from the use of the goods, whether used singly or in combination with other goods. Seller neither assumes nor authorizes any person to assume for seller any other liability in connection with the sale or use of the goods sold, and there are no oral agreements or warranties collateral to or affecting this agreement.

1.0 INSPECTION OF NEW CHASSIS

Before you start assembling your chassis, please take some time to first inspect it for any damaged, missing or defected parts. Granted, we do everything possible to ensure that every chassis that goes out the door is perfect but we are human and we make mistakes.

Equipment

Depending upon what chassis and package you purchased, standard and optional equipment will vary. Look over your kart and make sure you have everything you paid for. If you are unsure of something, please call your dealer or Phantom and inquire because now is the time to let us know.

What to inspect

Be sure to inspect your kart for all the required safety features such as safety pins in all the sanction-required places, brakes, all fasteners, and etc. Take added time to inspect the complete brake system. First inspect around all fittings and the complete system for any fluid that may have leaked during shipping. Check to make sure that the fluid reservoir is full. Next, pump the brake pedal to make sure the system is working properly and there is no air in the lines. Last but certainly not least, check to make sure all fasteners in the complete brake system are properly installed and tight. *For more details about your brake system, see section 6.0 on Brakes.*

Inspect all components of the steering system. After the steering upright is installed in race position, turn the steering system to it's full extents and make sure the system is free of any binding or loose motion. Inspect all fasteners and safety pins to insure they are properly installed and tight.

Finish your inspection by inspecting all bumpers, nerf bars, pedal assemblies and brackets. Be sure to check all fasteners, pins and clips to make sure they are in good condition and installed properly. From here, use your best discretion to determine the overall safety and workmanship of the chassis. If you are not satisfied with anything about your chassis, call your dealer or Phantom.

2.0 CUSTOMER CHECKLISTS

2.1 Phenom Standard Package

This is what you should receive with your standard Phenom kart package.

- Standard rear bearings and cassettes (upgrades available)
- Standard hubs and studs (upgrades available)
- Nylon brake lines (upgrades available)
- 13 1/2" PRC "Topless" steering wheel - black (color upgrades available)
- Standard seat (upgrades available)
- Set of seat struts and bottoms
- Accutoe Steering Lock

- 23" Steering shaft (other lengths available)
- Steering upright and Steering yoke
- Splined steering hub
- Bag of fasteners for the steering shaft, stg upright, stg wheel, seat and gear hub
- Owner's Manual
- Registration card
- Miscellaneous info & decals

If you did not receive everything on this list please contact your dealer. If the problem is still not resolved then please contact Phantom Racing Chassis.

Note: Standard chassis colors are Red, Black, and Clear anything else is an upgrade and there is an extra charge. The Phenom comes with L2 and R4 caster blocks for your reference.

Other options for Phenom: Jr. rods and pedal block assembly, different degree caster blocks (see section 4.2), L-05 caster block and 5 degree LF spindle for pavement, X-Factor spindles (see section 4.6), Jr. body kits, flat motor mounts, floor pan fuel tank, loop rear bumper, big billet brake system.

2.2 Phenom Champion's Edition Package

This is what you should receive with your Phenom Champion's Edition package.

- PRC Rear Axle Bearings and Cassettes
- RR collar hub, and bullet end studs in all hubs
- Steel Braided Brake Lines
- Choice of 1 Seat
- Set of Seat Struts & bottoms
- Set of WMS wheels-Dirt package: 2 - 10", 1 - 8 1/4" and 1 - 6 1/2"
- Set of Phenom Bodywork with Clear Driver's Bubble
- Body Bolt Kit
- Bubble Bracket
- PRC Black Aluminum 13 5/8" Steering Wheel (color upgrades available)
- Splined Steering Wheel Hub
- Complete Mega Mount (engine mount)
- PRC Bearing Oil
- 2-Axle Collars
- Locking Steering Block Kit (Accutoe Pro)
- Phantom Pedal Grips
- 23" Steering Shaft (other lengths available)
- Steering Upright & Yoke
- Fasteners for steering shaft, steering upright, steering wheel, seat and gear hub
- Owner's Manual
- Registration Card
- Miscellaneous Info & Decals

If you did not receive everything on this list please contact your dealer. If the problem is still not resolved then please contact PRC.

Note: Standard chassis colors are Red, Black, and Clear. Any other color is an upgrade and there is an extra charge. The Phenom comes with L2 and R4 caster blocks for your reference.

Other options for Phenom: Jr. rods and pedal block assembly, different degree caster blocks (see section 4.2), L-05 caster block and 5 degree LF spindle for pavement, X-Factor spindles (see section 4.6), Jr. body kits, flat motor mounts, floor pan fuel tank, loop rear bumper, big billet brake system.

2.3 Phenom Asphalt Upgrade Champion's Edition Package

This is what you should receive with your Phenom Asphalt Edition CE package.

- Thin Wall Rear Axle
- PRC Rear Axle Bearings and Cassettes
- RR collar hub, and bullet end studs in all hubs
- Steel Braided Brake Lines
- Choice of 1 seat
- Set of seat struts & bottoms
- Set of WMS wheels -Asphalt package: 2 - 10" and 2 - 6"

- Set of Phenom Bodywork with clear driver's bubble
- Body Bolt Kit
- Bubble Bracket
- PRC "topless" aluminum steering wheel in Black (color upgrades are available)
- Splined steering wheel hub
- Complete Mega Mount with wide top plate
- PRC bearing oil
- 2-Axle collars
- Locking steering block kit
- Phantom pedal grips
- 23" Steering shaft (std)
- L0-5 – LF Caster block
- R0 – RF Caster block
- 5 degree KPI - LF spindle
- X-Factor RF spindle
- Offset steering upright with yoke
- Fasteners for steering shaft, steering upright, steering wheel, seat mounting, and gear hub
- Phenom rear floor pan & bolts
- Owner's Manual
- Registration Card
- Miscellaneous Info & Decals

If you did not receive everything on this list please contact your dealer. If the problem is still not resolved then please contact PRC.

3.0 BASIC OVERVIEW OF ASSEMBLY

3.1 Steering Support/ Upright

Single Post Design

Your new Phantom Chassis is equipped with the all-new single post design steering support. Chances are, when you received your chassis the steering support was in the shipping position. It is very important that the steering support is properly installed and aligned again during final assembly. To ensure you properly align your steering assembly, follow this simple procedure. If you have any problems, contact your local dealer or Phantom for assistance.

1. In your kart kit, you will find a bag that contains your steering components such as the steering upright, upper steering block, yoke to hold the steering block and the misc. required fasteners.
2. First install the ½-20 jam nut on the ½-20 x 1 ½" bolt of the upper steering yoke and screw the steering yoke into the steering post. Be sure to use the jam nut and to screw the yoke *at least* ½" into the upright.

TIP: Before installing the steering yoke into the steering upright post now is a good time to apply some anti-seize compound to the threads. This is not required but may save you a headache down the road with future maintenance.

3. Insert the steering post into the frame and install the ¼-28 X 1 ½" SHCS **so that the head of the cap screw goes through the frame and tightens against the steering post.** To do this, install the cap screw into the frame from the side that has the largest hole (3/8" hole). If you install this bolt backwards, the steering post will have some loose motion. Install the ¼" flat washer and the ¼-28

Nylon lock nut and securely tighten. Don't forget the cotter pin! *Note: If you have the offset steering upright then you will have to drill your own hole(s) for the mounting bolt. Simply align the upright in position you want mark and punch where to drill the hole(s) and then install as normal once you have drilled the holes(s).*

4. Install the steering shaft (machined end, not splined end) into the 1/2" rod end in the lower steering support and install the 1/2" AN washer and 1/2-20 slotted hex nut. Be sure to tighten the nut and install the cotter pin! Install the upper steering block on the steering shaft. Raise the steering shaft to the desired height and install the 5/16"-24 x 2 1/4" hex head bolt with a 5/16" flat washer under the head of the bolt through the steering yolk and steering block. Use one 5/16 SAE flat washer and 5/16-24 NLN and securely. Tighten this bolt assembly *only!*

TIP: If you are going to utilize a bubble bracket go ahead install the bracket at this time and snug the bolt assembly. If you are not adding a bubble bracket, go ahead and tighten these bolts and install the cotter pin.

TIP: When installing your steering shaft into the lower rod end remember that this rod end height can be a fine adjustment in order to get your tie rods level and to give your steering the maximum performance. Also when tightening the 1/2-20 slotted hex nut that holds the steering shaft to the lower rod end make sure you do not over tighten or this may cause steering bind.

5. Now that the steering shaft and yoke are aligned, tighten the 1/2-20 jam nut for the steering yoke. *TIP: The steering shaft height can be adjusted in three locations... Three hole upper steering block, a fine adjustment with the upper steering yoke, and the steering post can be cut-off and redrilled for small drivers.*
6. Before you install the tie rods to the steering shaft, note how the bolt assembly is installed. There are four (4) 3/8" AN washers between the pitman arms. Two washers go between the top rod end and the pitman arm and the other two go between the bottom rod end and the pitman arm. *No washers go between the two rod ends!* One 3/8" SAE flat washer goes under the 3/8-24 x 2" HHCS bolt head and one under the 3/8-24 slotted hex nut. This assembly method will provide you with maximum steering travel and performance.
7. Install and tighten the tie rod assemblies with the short left side tie rod on the top position between the pitman arms. (at end)
TIP: Be sure not to over tighten the pitman arm bolt assembly or this may cause steering bind.
TIP: Phantom uses special Teflon lined rod ends. These rods ends have a Teflon lining between the inner ball and the outer housing which greatly increases the life of the rod ends. However, these rod ends do have a little more resistance than non-lined rod ends when they are new. As you run your chassis, the steering will loosen to a more comfortable feel. You can help speed up this process by spraying the rod ends with a light penetrating oil and working the steering rapidly when it is new.

3.2 Seat Mounting

Many racers do not realize the importance of seat location and how seat stress effects a chassis' performance. Because a kart is non-suspended, the chassis itself is the suspension in which it must act like a big spring. Anything you bolt to this spring in some way effects is performance. The seat is the largest and most rigid component that is bolted to the chassis and because it is bolted to the chassis with a large four-point pattern, it greatly affects the chassis flex. In-house testing has shown seats to effect chassis flex up to 10%. Combine the effects of chassis flex with the effects of the driver's body position to weight transfer, and the seat becomes a very important factor in winning races.

We're not trying to make you afraid of mounting your seat; we are trying to educate you about the importance of doing it correctly. If you will follow this simple procedure, you will find the job of mounting your seat much easier and rewarding.

Before you start mounting your seat you must first determine what position is best to start with for your driver and situation. All this takes is a little thought and common sense.

- 1. Left to Right Position.** Take into consideration the size of the driver and your track configuration and condition. If you feel that you need high left side weight percentages then you want to mount the seat more to the left. On the contrary, if you feel that you need more side bite, then mount the seat more to the right for added weight transfer.
- 2. Front to Rear Position.** Obviously this controls the nose weight so determine what range of nose weight you're going to start with. The driver's build greatly effects the nose weight of the kart so take into consideration where your driver is carrying the bulk of his/her weight; high, low, or in the middle. Take this information into consideration with what percentages you want to end up with on the scales and determine how far forward or back you want to mount the seat.
- 3. Seat Height.** Again consider the driver's build and your track information to determine how high to mount the seat. If you feel more weight transfer is needed for your situation then it's best to mount the seat in a high position. For less weight transfer, mount the seat in low position but be sure to stay within the rules and safety limits.
- 4. Rotation.** If you stand at the rear of your Phantom Chassis, you will see that the drivers cockpit is not parallel to the direction the chassis rolls. Notice that the steering shaft points almost to a one o'clock position. This is the same angle that you want to mount the seat.

How it's done:

- By now you should have a good idea what position you want to mount your seat. Start by adjusting the front seat slides out to an even amount and slightly tighten the 1/4-28 SHCS just enough to hold in place.
TIP: If you do not have a partner helping you, use some sort of a "stiff knee" to hold up the back of the seat while you position the seat in the kart for measuring. Drill a 5/16" hole in the end of a short piece of bar stock (approximately 1/8" x 3/4" x 3" long). Remove the top nut from the brake caliper and put the bar stock over the bolt. Replace the nut and lightly tighten so it can be adjusted as needed. Be sure to remove this bar stock after the seat is mounted and replace the nut and safety pin!
- Using the stiff knee or your partner, position the seat in the kart as you are intending to mount it. Inspect and measure the seat from all angles. Adjust the seat slides and the stiff knee until you have the seat positioned exactly as you are going to mount it.
TIP: Be sure you have the rear seat height correct at this point and that the bottom of the seat is also positioned on a parallel plain with the bottom of the frame. To meet the 14" seat height rule, the top center back of the seat must measure a minimum of 8 3/8" off the top of the axle with the axle in the bottom holes (std. position). This seat height measurement may vary depending on what class you run and your sanctioning body or tracks rules, so check your rules before deciding on this. Also your axle position, tire circumference and air pressures will affect it as well when you are at the track.
- Once you have the seat in position, mark the two bottom holes with a marker or scribe. Drill the two marked holes with a 21/64th drill. Mount these two holes using the correct hardware supplied in the "kart kit." Be sure to use (1) 5/16"-24 x 1 1/4" BHSC screw, (1) 5/16" fender washer, (1) 5/16" SAE washer, (1) 5/16"-24 nylock nut and (1) rubber grommet for each assembly. Tighten each assembly just enough to slightly compress the rubber grommet.

TIP: When marking your seat mounting holes do not forget to take into consideration the thickness of the rubber grommets. Especially on the bottom holes if you do not allow for this you could raise or lower the seat position when you install the grommets.

4. Check to make sure the seat is still in the correct position. Mount the left side seat strut on the left side nerf bar tube and tighten slightly so it can be adjusted as needed. Position the strut up to the seat in the mounting position with approximately $\frac{1}{4}$ " clearance between the strut and the seat. Check your rear seat height. Mark and drill the hole with a $21/64^{\text{th}}$ drill. Mount and tighten with the same type hardware as the front mounts.

TIP: Depending upon the style and size of seat you use, you may need to slightly bend the mounting area of the seat struts and seat slides to match the seat itself. We take great efforts to manufacture these parts to prevent this but it is impossible to make them so they will match every seat perfectly. The rubber grommet should compress evenly and not just on one side.

5. Repeat this same procedure for the right side strut.

TIP: All holes should line up without having to put the seat or chassis in a bind. If you have to manipulate the seat over $\frac{1}{4}$ " to install the bolt, you should drill another hole.

6. Now that all points of the seat are mounted, securely tighten ALL fasteners EXCEPT the two $\frac{1}{4}$ "-28 SHCS seat slide bolts. After all the other fasteners are properly tightened, loosen the two $\frac{1}{4}$ "-28 SHCS seat slide bolts. With them loose, twist the front of the seat to ensure the seat is not in a bind. If the seat appears to be in a bind, remount the seat. If not, securely tighten the seat slide bolts and the jam nuts.

7. Be sure to remove your "stiff knee" and replace and tighten any fasteners that were altered. The seat is done!

TIP: You should periodically check your seat to make sure all mounting points are secure and that the seat is not in a bind.

3.3 Steering Wheel Mounting

All the necessary hardware to mount your steering wheel is included in your kart accessory kit. Please take time to inspect each piece before you use it to make sure they are free from any defects.

1. The splined steering wheel hub is equipped with two different hole patterns to accommodate a variety of steering wheel patterns. Match the correct pattern to your steering wheel and install the three $\frac{1}{4}$ "-28 x $1\frac{1}{4}$ " hex head bolts (with end drilled for safety pins) through the steering wheel first then through the hub.

TIP: If you plan on utilizing a tachometer now may be a good time to mount your tach bracket if it mounts on the steering wheel.

2. Now install one $\frac{1}{4}$ "-28 NLN (Nylon lock Nut) on each bolt and securely tighten. Was tight be sure to install the safety pins in the end of each bolt.
3. Install the $5/8$ " external snap ring over the splined end of the steering shaft and into the groove at the end of the splines.
4. Install the steering wheel that is already mounted to the splined steering wheel hub over the splines of the steering shaft. Be sure to position the steering wheel per the driver's comfort and in relation to the seat position.

TIP: If you are utilizing a locking steering block make sure that you have installed the steering block locking collar and the locking pin's cable on the steering shaft before installing the steering wheel.

3.4 Setting Toe

3.4.1 Setting Toe with the Accutoe Pro

The Accutoe Pro is an extremely accurate laser alignment system when used correctly. Please read the following instructions to insure you can get the most out of your new Accutoe Pro.

The objective of the Accutoe Pro system is to align the front and rear axles of a chassis by projecting a laser beam between the two axles in a reflective manner.

Instructions for Standard Accutoe Pro System

Aligning the right side. *The left side can be substituted if desired.*

1. Place your kart on a stand and remove all four tires and wheels.
2. Lock your steering shaft into the desired position (usually with pitman arm at a 90° angle to the tie rods). Having a steering lock that will consistently repeat this location is required. The optional Accutoe Pro steering lock (# 1145210) is recommended.
3. Install the laser hub bracket on the right rear hub and attach the laser to the bracket with the supplied thumbscrew*. Install the laser so it points toward the front of the kart from the underside of the axle.
4. Remove the right front hub and hub spacers. Install the mirror bracket on the right front spindle axle so the mirror faces the rear of the kart from the underside of the spindle axle.
5. Turn the laser on by pressing the button on the rear of the laser housing and aim the laser so it hits the mirror in approximately the horizontal centerline. *(Please note that some chassis may require adjusting the mirror bracket or the rear hub in or out to allow the laser to intersect the mirror.)*
6. Pivot the mirror bracket on the spindle axle until the reflected laser beam is at an approximate height to intersect the laser housing.
7. Adjust the spindle tie rod in or out until the reflected laser dot is aligned with the centerline on the laser housing. Be sure to jam lock your tie rod into position.
8. Turn the laser off and remove the Accutoe Pro in reverse manner from which you installed it.



Aligning the left side. *The right side can be substituted if desired.*

9. Repeat steps 3 thru 6 from above on the left side of the kart.
10. With the scale attached to the laser housing, adjust the spindle tie rod in or out until the reflected laser dot is aligned with the scale line indicating your desired toe setting.
TIP: Most karters desire toe-out. For toe-out you should mount the laser so the scale is pointing in toward the center of the kart (right or left side). If you desire toe-in, simply flip the laser over so the scale is pointing outward from the kart.
11. Be sure to jam lock your tie rod into position.
12. Turn the laser off and remove the Accutoe Pro in reverse manner from which you installed it.
**TIP: Do not use any other fasteners to attach the laser other than those supplied with this kit! Using different fasteners can permanently damage the laser. NEVER screw a bolt into the side of the laser other than noted here! Please note that if you have to remove or install the scale to the laser housing it is important that you align the “zero line” of the scale with the centerline on the laser housing.*

3.4.2 Setting Toe with the Accutoe Pro Expansion Kit Option

The expansion kit allows you to align your chassis in an “as raced” form with wheels tires and driver in place. The accuracy of the Accutoe Pro System is the same but some racers prefer this method over the “knocked-

down” version.

Aligning the right side. The left side can be substituted if desired.

1. With your kart and driver sitting on a flat surface (preferably your scales), remove the rear snap rings and front spindle axle nuts along with the outer hub spacers.
2. Lock your steering shaft into the desired position (usually with pitman arm at a 90° angle to the tie rods). Having a steering lock that will consistently repeat this location is required. The optional Accutoe Pro steering lock (part# 1145210) is recommended.
3. Install the rear axle extension over the end of the axle so all four thumbscrews will contact the axle and tighten.
4. Install the spindle axle extension on the front spindle so the end of the axle bottoms-out inside the extension.
5. Screw the laser directly to the rear axle extension with the installed ¼ x 20 stud and lightly hand tighten. Rotate the rear axle assembly until the laser is pointed forward in a horizontal plane.
6. Install the mirror bracket on the front spindle axle extension so the mirror faces the rear of the kart from the underside of the spindle axle.
7. Turn the laser on by pressing the button on the rear of the laser housing and aim the laser beam by rotating the rear axle so it hits the mirror in approximately the horizontal centerline. *(Please note that some chassis may require adjusting the mirror bracket in or out to allow the laser to intersect the mirror.)*
8. Pivot the mirror bracket on the spindle axle until the reflected laser beam is at an approximate height to intersect the laser housing.
9. Adjust the spindle tie rod in or out until the reflected laser dot is aligned with the centerline on the laser housing. Be sure to jam lock your tie rod into position.
10. Turn the laser off and remove the Accutoe Pro in reverse manner from which you installed it.

Aligning the left side. The right side can be substituted if desired.

11. Repeat steps 3 thru 8 from above on the left side of the kart.
12. With the scale attached to the laser housing, adjust the spindle tie rod in or out until the reflected laser dot is aligned with the scale line indicating your desired toe setting. *Please note that most karters desire toe-out. For toe-out you should mount the laser so the scale is pointing in toward the center of the kart (right or left side). If you desire toe in, simply flip the laser over so the scale is pointing outward from the kart.*
13. Be sure to jam lock your tie rod into position.
14. Turn the laser off and remove the Accutoe Pro in reverse manner from which you installed it.

WARNING! This tool contains a laser! Lasers are very dangerous if not handled properly! Lasers can permanently damage the eyes of humans and/or animals. Do not direct this or any other laser into someone’s eyes. Lasers are not toys and should be kept away from children at all times! Think Safe!

3.4.3 Setting Toe with the Original Accutoe

The following directions, use the Original Accutoe by Phantom. The Original Accutoe kit can be substituted with a right rear tire, piece of string and toe plates. Using the Original Accutoe greatly reduces the margin for error but with a little care, accurate results can be obtained the “old-fashioned way.”

Instructions:

1. Assemble rear toe plate by putting the axle tube through rear toe plate hole until tube is flush with toe plate. Note that the end of the tube without holes drilled in it is the end that goes through the plate. Also note that the holes should be turned towards the front of the plate and kart. Then put the $\frac{1}{4}$ 20 x $1\frac{1}{2}$ SHCS through the drilled and counter sunken end of the plate, which should be up. Next, place the two small wing bolts through the tube, making sure that they do not go all the way into the tube.
2. Replace your standard steering shaft block with the locking steering block that is included in the kit. **Be sure to install the block with the $\frac{1}{8}$ " hole to the topside.**
3. Make sure that the bolt in the steering lock collar is loose and then slide it over the steering shaft until it is just above the steering block. Loop the cable of the locking pin over the steering shaft itself and install the pin through the center hole of the steering lock and into the steering block. **(The cable is designed to attach around the steering shaft itself in order to hold the pin when not in use)**
4. Position the steering shaft until the pitman arm is perpendicular to the tie rods. This is what we refer to as centering the steering. Now securely tighten the steering lock to the steering shaft.
5. Remove the front hubs and spacers from the spindles. Place the front toe plates first on the spindles and replace one wide spacer with the toe plate, then put hub and spacers back on spindle and tighten up with the spindle nut. Note that the toe plates should be horizontal, or level with the chassis.
6. Place the axle tube (or a straight tire & wheel) on the right rear, it will only go on one way, and that is with the end of the tube that has the two small wing bolts. It will be necessary to remove the snap ring on the axle before placing the tube on the axle. With the toe plate facing forward, lock the tube down by tightening the two small wing bolts.
7. *Phantom* recommends using a 4-foot level (or a piece of string if you're using a tire & wheel) for this operation. Place the level flush against the rear toe plate as shown in Diagram 3.4.3. Measure from the front of the toe plate to the level and again from the rear of the toe plate to the level as shown. Adjust the right tie rod until these measurements are even, front and rear.
8. Measure from the right front to the left front of the toe plates, and again on the rear of the front toe plates, and set your toe accordingly and tighten jam nuts at this time. Remember that if the number from the front of the toe plates is smaller than the number from the rear of the toe plates, *you are toed in*. If, the number in the front of the toe plates is larger than the number from the rear of the toe plates, *you are toed out*. I.E.: Front=28" Rear=28" (no toe) Front=29" Rear=27" (toed out) Front=27" Rear=29" (toed in) these are only used for examples, *not actual setup*.
9. Now the toe is set, it will be necessary to remove the toe plates, and axle tube. Also remember you must remove the $1\frac{1}{4}$ -20 x $\frac{3}{4}$ SHCS from the steering block or you will not be able to steer.

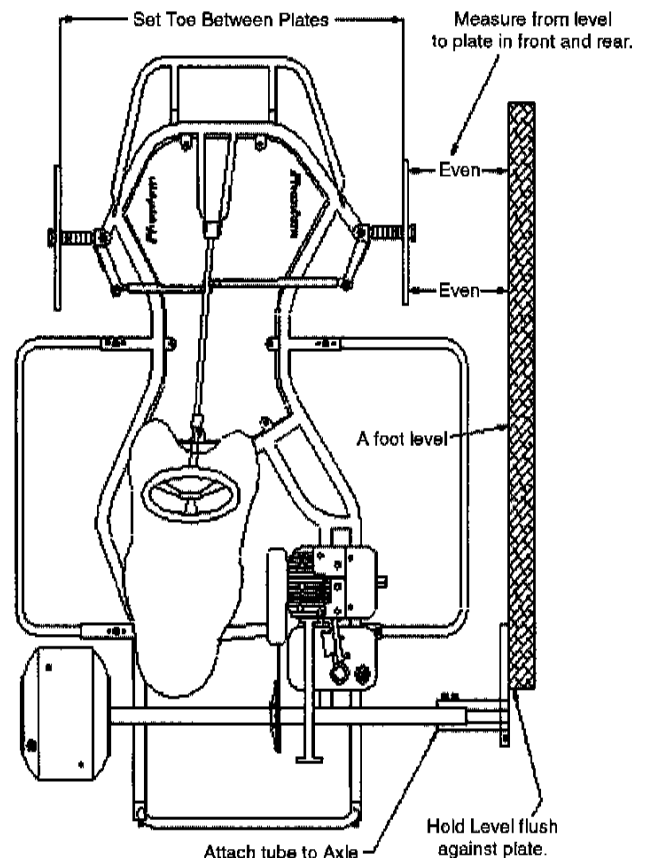

10. Check over your rod end jam nuts to ensure they are tight and ready for competition.

3.5 Body Work Mounting

Much like the seat, bodywork can also affect the performance of your chassis. Properly mounting the body is also important to achieving maximum performance from your kart. We will not attempt to cover every detail of how to mount your body because each style body requires a little different detail. The following is a quick overview to aid you in the process.

Phantom manufactures a body specifically designed for each model. We also have a video available that takes you step by step through the mounting of a body. Call your dealer or Phantom and ask for it by name, *From the Box to the Track™*.

1. Mount a set of tires on the kart that are relative to the sizes you are expecting to run. Stagger, compound and air pressures are not important at this time; we simply need something to line the body to.
2. Put the kart on a flat surface and place the nosepiece over the front bumper. Place a spacer under the bottom of the nose to bring the nose up level with the bottom of the kart (A 2-by-4 works well).
3. Position the nose so it is centered over the wheels and so the wheel-wells are centered with the tires. Drill and mount the nose at the front.
4. If needed, install brackets to allow front tire clearance under nose. (Brackets are available from Phantom and come standard with the Champion's Edition™.) These brackets should only apply a minimum amount of pressure to allow tire clearance. If you feel that an excessive amount of pressure is applied, that particular nose should not be used or something is not properly aligned.
5. Position side panels/pods to fit the nerf bars and align with the nose. Be sure to check that nerf bar widths are within technical requirements. These requirements can be found in your sanctioning body's tech manual.

TIP: If you are mounting a body that the sides connect to the nose, you may have to trim the back edge of the nose to get a perfect match between the sides and the nose.

6. After you make sure everything is properly positioned and trimmed, fasten the sides to the nose and then to the nerf bars. Three fasteners between the nose and the side panels on each side are sufficient. Putting too many fasteners will restrict chassis flex.
7. If you are utilizing a driver's bubble and bracket now is the time to install them. If you did not mount your bubble bracket when you were assembling your steering earlier then you need to mount it now. Install the bubble bracket to the steering column with the supplied 5/16"-24 x 2 1/4" hex bolt. Then mount the driver bubble (fairing) to the bracket in a manner that it does not restrict the driver's vision or ability to exit the kart.

TIP: When mounting your driver's bubble make sure you check your rule book for mounting specs. Normally the bubble has to be 3" from the steering wheel for hand clearance and 6" from any bodywork.

8. Take time to go back over the complete body and do any trimming or sanding to make your job complete. Also take time to check behind yourself to make sure all fasteners are secure and free of potential safety problems. Use your best discretion with any safety concerns because the final decision is yours.

TIP: We recommend that you use all Phantom original body components to get the proper fit and ultimate performance out your chassis. Whenever you are deciding on any style body work consult your rule book for any regulations that may affect what you use and how you mount it.

Using 1/4 -Turn Fasteners ("Dzus" style)

1. Identify the mounting brackets on the nerf bars and the front bumper. Inset the rivets with the long ends facing away from the bracket. Place the spring with the open ends facing the bracket and rivets. Use .250 spring for the front bumper brackets, .300 for the nerf bar brackets.
2. Drill a hole for the 1/4 turn fastener in your bodywork. Insert the fastener and use the plastic washer to secure the fastener to the bodywork.
3. Use an 3/16 Allen wrench to lock the fastener on to the spring.
4. When changing bodywork, just unlock the fastener from the spring and remove the sides or nose.

3.6 Other Hardware Mounting

Now it's time to mount any other hardware that you intend to have on the kart during competition. This will include things such as motor, drive train, oil catch can, tach, etc... Anything you bolt to the kart will affect the weigh-out so you need to get them all on at this time. There are other publications that will help you with this step but the most important thing to remember is **safety first**. Be sure to check behind your work. **Note: Please see enclosed Setup Sheet for numbers to give you a starting point for weighing out your kart.**



4.0 PHENOM SETUP INFORMATION

4.1 Phenom Caster Information

Caster Block Design: Two ways to set your Caster

Your new Phenom incorporates a **Caster Block Design** that allows you two different ways of setting caster. One, Phantom makes several different Caster Blocks for each side that will achieve different caster settings (see diagram 4.1 A.). **This is the more accurate of the two ways and this is the way we recommend setting your caster.** Second, each caster block is marked on the top to allow you to infinitely adjust your caster. If you remove the top pin from the frame, you can rotate the caster block around the center pin to adjust the caster. This gives you the ability to set your caster to any degree you desire but you will lose some accuracy over using the dual pin design.

If you choose to set your caster to an odd number such as 7°, 9° or 11° you will need to set the centerline on the frame between the two appropriate marks on the Caster Block. Please note that the right front of the Phenom has adjustable lead. You have the choice of two different lead settings. This lead difference causes the need to have two different centerline marks on the right front frame plate. Be sure to use the correct centerline mark for the lead setting you are using.

What to expect from changing caster

The intent of these blocks is to tune the feel of the kart to compliment the driving style of the driver. Please **DO NOT** commonly change these blocks in the middle of a race day to accommodate track conditions. The major difference you will see when you change caster is in the drivability of the kart. Lower caster causes the kart's steering to have **much less resistance** and may cause less experienced drivers to become darty or jerky. For this and other occasions, you may find that using a "non-recommended" caster may work to your advantage.

4.2 Phenom Camber Information

If you are not accustomed to the "reverse yoke" design or the camber adjustments of the Phenom, please take a few minutes to look over Diagram 4.2 and notice how it all works. The better you understand your chassis, the better it will perform for you.

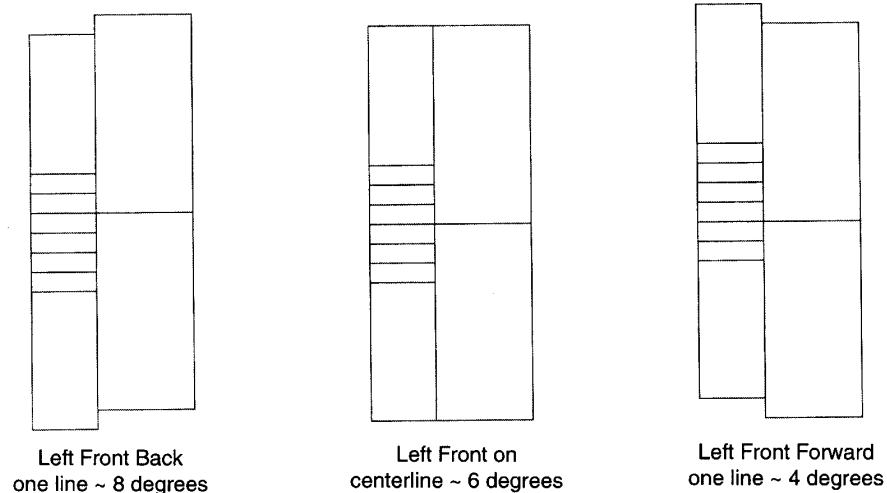

The new Phenom allows the simplest camber adjustment of any chassis on the market today. You do not need to take the spindles off or the kingpin bolts out... you adjust the camber with the kart on the scales and the driver in the seat. Notice in Diagram 4.2 that the kart has an inner and an outer jam nut on the top ball joint. By adjusting these nuts in the direction that is noted in the diagram at the top the page you can adjust your camber accordingly.

Through our testing, we have found that we can get better results out of adjusting camber than adjusting caster. From there you must take driver feedback, tire temperatures and the overall speed of the kart into consideration when adjusting your camber. Each driver will find a particular camber setting that will suit his/her driving style the best. No one can do it for you or tell you what will work the best for you. That's up to you.

Please note that you should only compensate for one condition. Do not add up several lines to come up with a major change. Also note that these are just recommendations for a starting point. If you find something that works better for you in your situation, please use those settings.

Recommended Camber Settings for the Phenom

<i>Track Configuration</i>	<i>Left Front</i>	<i>Right Front</i>
Flat Dirt Track	+ .25 to + .5	-2 to -2.75
Banked Dirt Track	+ .5 to + .75	- 2.75 to -3.5
Flat Asphalt Track	+ .25 to +1	-2.25 to -2.75
Banked Asphalt Track	+ .5 to +1	-2.75 to -3.5
<i>If your track is (Compensate for only one)</i>	<i>Left Front</i>	<i>Right Front</i>
Hard & Dry	Reduce -.5	Increase +.25
Damp & Tacky	Increase +.5	Reduce -.25
Small & Tight	Increase +.5	Increase +.5
Large & Sweeping	Reduce -.5	Reduce -.25

These settings are actual camber as checked with a camber gauge! ***Be sure to recheck your toe after making a major camber adjustment!*** For more information about how camber settings effect a chassis, get your copy of *Top Secret* or *Caster & Camber* or join the *Top Secret Video Club* so you can stay up to date on the latest secrets of the Pros!

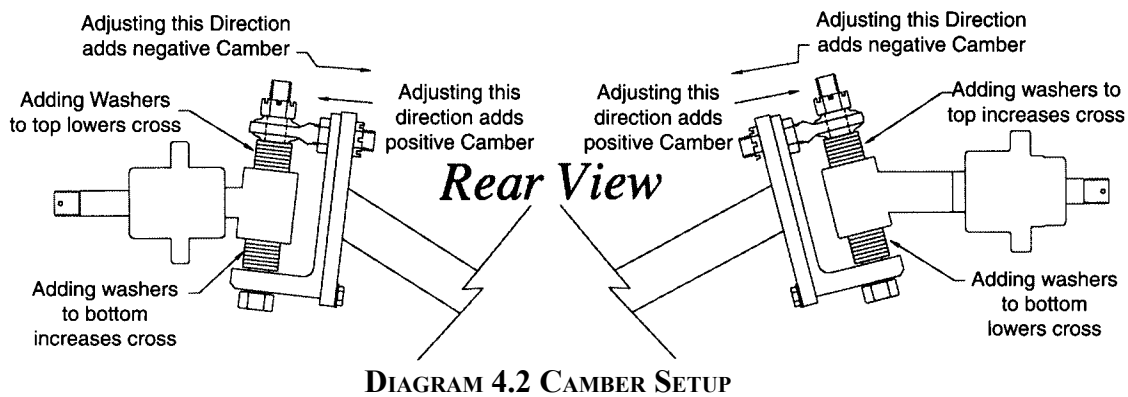

4.3 Phenom RF Adjustable Lead

The Phantom Phenom is equipped with a feature that allows the racer to adjust the lead in the chassis to fit his/her driving style. If you will notice, the right front camber plate utilizes threaded pins instead of dowel pins. These threaded pins can be removed with a 5/32" Allen wrench and installed in an optional set of holes that shortens the right side wheelbase by 3/8". Reducing the lead will often times make the front end of the kart more responsive. Each racer will need to experiment with the different settings to see which one better suits his/her driving style and track conditions. Be sure to check your toe and camber settings after you change the lead!

NOTE: Right Front Frame plate has two lines for the different lead settings. Be sure to use the correct line.

4.4 Weigh-Out Information

Please see the enclosed Setup Sheet for numbers to give you a starting point when weighing out your kart.

Remember

When you are weighing out your kart, have everything as you intend to race. Meaning, set your stagger, air pressure, type of tires and etc. just like you are going to head out onto the track except put it on the scales. Changing these variables after you weigh-out your kart will cause you to become confused when you start to make changes at the track. If you know how the kart is weighed in a certain condition, you can make more educated decisions.

Please Note

Every time you weigh-out your kart, you may be adding, removing or just moving around ballast weight. Please notice that the weight brackets on the chassis are limited to 5 pounds per bracket. Using more than the maximum 5 pounds can cause these brackets to fail. Also use a minimum 5/16" Grade 8 bolt, double nut and cotter pin. Also, to prevent damage to the weight brackets, use a rubber grommet between the ballast weight and the bracket. These precautions will ensure the safety of you and your competitors. (See diagram on p. 24)

Scaling your chassis is one of the most important steps in having a successful chassis setup. Spending a little extra time scaling your chassis will save you time getting around the track!

It's VERY important that you have a good set of scales and have them set-up properly. Throwing a set of bathroom scales onto a concrete floor is better than nothing but not very accurate. If your scales are not properly

level, your final numbers will not be accurate either. Consider this... one spindle washer is 1/16" thick, so for every .060 that your scales are out of level, that equals one spindle washer.

For more information about setting up your scales and how different types of scales affect your weigh-out, get your copy of *From the Box to the Track* video or *Scales & Chassis Dynamics* video.

Many racers experience the cross weight of a kart changing from one run to the next or even from one time on the scales to the next. The leading factor to this is tires and in what position they come in contact with the scales. Kart tires are bias-ply, which results in excessive run-out (high and low places). Allowing the tires to sit on the scales at different rotations will result in the cross weight varying up to two percent. Even though this has nothing to do with the chassis, the chassis is always the first blamed. One good habit that will correct this problem is to always place the valve stems of the wheels in the same location when you weigh-out your chassis. This will save you some confusion and save Phantom a phone call.

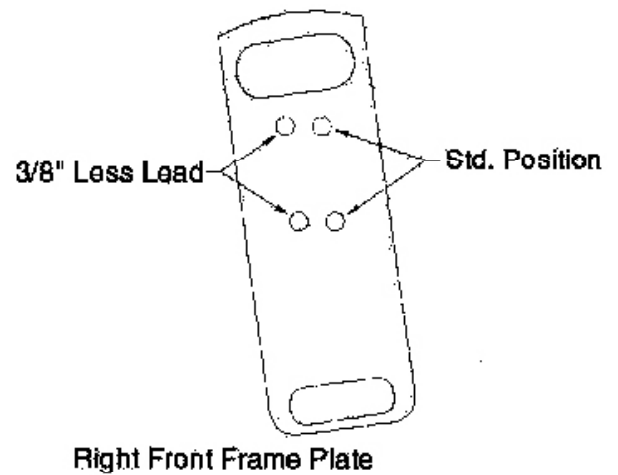

DIAGRAM 4.3

4.5 Phenom Spindle Options

X-Factor Spindles

All Phenom chassis are shipped with the standard spindle package, which is the most popular throughout the industry. However, many racers choose to run high amounts of cross weight, which causes them to move the spindle washers to the extreme on both sides. The new X-Factor spindles are designed to add cross to your Phenom without moving so many washers.

These spindles are sold separately and can also be used separately depending upon the amount of cross weight the racer needs to add. Each spindle will add approximately 4% of cross weight... that's approximately 8% total if you run both X-Factor spindles. If your situation requires running high cross weight then you should ask your Phantom Dealer about the new X-Factor spindles today. (*X-Factor spindles part #'s – 1111007L left front – 1111007R right front*)

5° Spindle and Block

The 5° spindle and Castor Block are designed specifically for asphalt applications, but many dirt racers have learned to use it to their advantage as well. This setup changes the left front KPI from the standard 10° to 5°. The main difference you will see in your chassis' performance is the amount of front-end bite that the kart will have. This setup will allow the kart to turn better in the center of the corner.

Please Note

The 5° spindle (part# 1111006L) must be used in conjunction with the 5° caster block (part# 111135L05), and cannot be used separately. Also, the 5° setup is only available for the left front.

Almost done!

Now you're ready to start burning the track up! Not quite! **Please take time to go over your work and make sure everything is safe.** Check all fasteners to make sure they are tight and that all necessary cotter

pins are in place. A little time now could not only save you from falling out of a race, it could save you or your driver from injury.

Racing is a dangerous sport. Wiggins Kart Shop, Inc. and/or Phantom Racing Chassis® is not liable for injuries that may occur while using any product/s we sell and/or manufacture. The final decision of the safety and use of any product is the responsibility of the user. The user accepts all responsibility. All products that are sold by Wiggins Kart Shop, Inc. and /or Phantom Racing Chassis® are intended for professional racing ONLY!

5.0 BEARING MAINTENANCE

5.1 PRC Lubable Rear Axle Bearings

If your kart is equipped with PRC Lubable Rear Axle Bearings, please take a few minutes to read and follow this section in order to get the maximum life and performance out of these bearings. With proper maintenance, these bearings may very well outlast your chassis.

Please note that the 1999 and newer PRC Lubable Cassettes are equipped with a pinch bolt design. This pinch bolt is to enable you to achieve a specific bearing to cassette fit and **not to be used as a chassis-tuning tool**. This pinch bolt and the bearing fit is preset at the factory and should not be adjusted until you feel that the bearing fit has changed due to wear. At which time, you must **remove** the bearing and cassette from the axle and readjust the pinch bolt. The bearing fit should be set to where the bearing has no side or up and down “play” but will still pivot inside the cassette with the effort of your hands. Please be aware that small adjustments of the pinch bolt will cause the cassette to lock the bearing from pivoting so be sure to take your time.

PLEASE NOTE: That your bearings are pre-lubed at the factory, so there is no need to add additional lubrication prior to use. After you put your chassis into use, **you should lube the bearings each week**. The amount of oil needed each week will depend upon the amount of contaminates your bearing run in. If you run on a dusty dirt track you will want to use enough oil to flush the dust and dirt out of the seals before you leave the track. But if you run on an asphalt track, you will only need to add a few drops each week to replenish the oil that was wasted through normal use. Be sure to remove any excess oil that may accumulate around the outside of the bearing. If this excess oil is left on the outside it will cause dust, dirt, and other contaminates to stick to the outside of the bearing. If left, such contaminates will work their way into the bearing and cause the bearing to fail.

It is important that you use the correct type of oil to achieve maximum performance. Along with your chassis, you received a 2 oz. bottle of oil. We have found this oil to perform very well under racing conditions. This 2oz. bottle should last for a few weeks of racing and additional bottles can be purchased at your Phantom Dealer (part # 1115510). Bottles of Performance Bearing Oil are also available in a 6.0oz size. (part # 1115509)

ALSO NOTE: When you wash your chassis, **DO NOT use high-pressure water or air around the bearings!** Even the pressure of a garden hose can force water and grit past the seals and inside the bearings. Once this grit is inside the bearings it will cause the bearing to fail. Simply wipe the grit from the outside of the bearings with a rag and flush the bearings out with the oil listed above. This will clean the seals from the inside out and greatly prolong bearing life.

Tightness or Tight Spots

Should your axle assembly suddenly become tight or have a tight spot in the rotation, chances are the bearings have somehow gotten in a bind. The fix is simple. Simply loosen one of the bearings from the axle. To do this, loosen the setscrews that lock the inner race to the axle and loosen any axle collars that may be used. Spin the axle and see if the tight spot or tightness is gone. If it is, retighten the setscrews and axle collars and

you're ready to go. If this does not remedy the problem, the bearings may be bound to the cassette. If that is the case, try tapping the cassette firmly with a rubber hammer while spinning the axle.

Should you ever remove your bearings from the cassettes, refer to the diagram below to ensure you properly assemble them again. Be sure to align the oil hole in the cassette and the bearing, and to install the line-up pin under the SHCS.

5.2 Kingpin Bearings

The kingpin bearings are shielded bearings that are routinely replaced. These bearings are under a high load that causes them to fail. Since these bearings control your front geometry, it is a good idea to replace the bearings a couple times per year.

PLEASE NOTE... these bearings have a spacer between them that must be used. Without this spacer, the inner races of the bearings will break. Make sure that your kart has these spacers and that they touch the inner race of each bearing.

These kingpin bearings are put into the chassis or spindle with a very light press to prevent damaging the small bearings. Should one of your bearings continually slip out when you change your spindle washers, clean both surfaces good with a mild solvent and reinstall the bearing with a few drops of Loc-Tite around the outside.

Your king pin bearings for the most part are maintenance free. These bearings are grease filled and sealed to prevent dirt from entering the bearing under normal conditions. It is important that you clean around these bearings for the bearings to work properly. Any dirt or grit that may accumulate around the outside of the bearing should be wiped away with a rag. You can lubricate the bearings with some light grease or WD-40 will do fine just to prevent any friction with the king pin bolt and to keep your steering free. If the bearings become worn or will not function properly then it is time to replace them.

5.3 Standard Rear Axle Bearings

If your kart is equipped with Ultra-Free Rolling (UFR) axle bearings, please take a few minutes to read this section so you properly maintain them. Please be aware that Phantom uses the highest quality UFR bearings available but all UFR bearings have their drawbacks. In order to achieve the UFR characteristics, the seals are replaced with dust shields and they have very lightweight oil. This provides for a very free rolling bearing but it also reduces the durability.

The dust shields can allow fine dirt and grit to enter into the bearing. It is important to keep the outside of these bearings as clean as possible. Allowing grit to remain on the outside of the bearing will allow it to work its way inside and destroy the bearing. Any dirt or grit that may accumulate around the outside of the bearing

should be wiped away with a rag. DO NOT use high-pressure water or solvents to remove this grit. The high pressure will force the grit past the shields and into the bearing.

Because these bearings do not have any seals to retain the lubricating oil, this oil is eventually allowed to escape and the bearing will fail. Some racers remove the bearings from the axle, clean them and soak them in oil. If done properly, this is very effective but the key is to keep the grit out of the bearings. Just expect to replace these

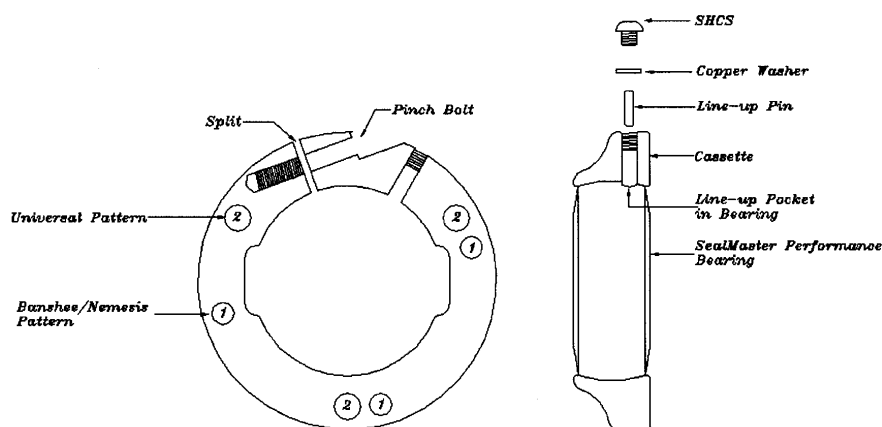

bearings sometime in the future. An alternative to the UFR bearings is the Lubable Performance Bearings. If the UFR bearings will not withstand the elements that you race under, ask you Phantom sales representative about the Lubable Performance Bearings.

5.4 Front Hub Bearings

Your front hub bearings are for the most part maintenance free. These bearings are grease filled and sealed to prevent dirt from entering the bearing under normal conditions. It is important that you properly clean around these bearings in order for these seals to work properly. Any dirt or grit that may accumulate around the outside of the bearing should be wiped away with a rag to prevent the grit from eventually damaging the seal. **DO NOT** use high-pressure water or solvents to remove this grit. The high pressure will force the grit past the seal and into the bearing.

After the hub bearings have been run for some time and start giving problems, it's best to just replace the complete bearing. Removing the factory seals to clean and re-lubricate the bearings is sometime effective but often the factory seals are damaged.

PLEASE NOTE: if your front hub is equipped with a spacer between the bearings. All hubs with identical size bearings are originally equipped with a spacer at the factory. This spacer allows you to firmly tighten the spindle nut to eliminate any play on the spindle shaft. If there is no spacer between the bearings, the nut can only be finger tight. ***The Phenom right front hub does not allow a spacer and should only be finger tight.***

6.0 BRAKE INSPECTION AND MAINTENANCE

When it comes to your driver's safety, there is nothing more important than your brake system. You should inspect the complete brake system each week for things such as fluid level, pad wear, pad gap, fluid leaks, loose fasteners, and etc. Anything that may look suspicious or unsafe in the brake system should be addressed and fixed before the kart is put back on the track.

6.1 BLEEDING INSTRUCTIONS

1. Be sure all hydraulic connections are secure. Never use Teflon tape to seal the fittings in the castings. An appropriate Teflon paste like that used from the manufacturer is recommended. The high-pressure tubing should be inserted completely into the cap and ferrule. From finger tight, the fitting cap should be tightened two turns. This should leave a gap of about .050" between the cap and the hex part of the fitting body.
2. Remove the filler plug from the master cylinder top and fill reservoir with *dot-5 silicone brake fluid only!* Stroke the master cylinder lever arm a full stroke and open the bleed screws on the caliper for about two seconds then close. Allow the master cylinder arm to return to the rest position and wait approximately ten seconds to allow for the fluid in the reservoir to transfer into the bore of the master cylinder. Repeat the process of stroking the master cylinder again, open and close the bleed screws the same as before wait again. Continue this procedure until a firmer pedal is realized (depending on the length of line used, this will probably be four to six times)
3. After the pedal has become reasonably firm, take shorter strokes of the master cylinder with the bleed screws open so as to allow only a short spurt of brake fluid to escape. For the finishing process the brake pedal should be held down firmly as possible before opening the bleed screws to purge as much air with the escape of fluid as possible.
4. Check all hydraulic connections for any possible fluid leaks.

6.2 Caliper Rebuild Instructions (Part #: 15352)

Disassembly:

1. Remove, caliper from kart and remove brake lines.
2. Remove the brake pads using a 3/16" Allen wrench.
3. Wrap a rag around caliper and hold the caliper body with the piston facing down and away from you.
4. Now carefully blow air into the fitting with an air hose until piston blows out of bore.

Clean and inspect:

1. Clean all parts in a cleaner such as mineral spirits.
2. Examine the bore for any unusual wear.
3. Sand bore by hand with #600 grit sand paper, recheck and re-clean.

Assembly:

1. Lubricate the bore with silicone brake fluid, WD-40, Triflow, etc.
2. Install new piston in bore.
3. Install pads and tighten to 110-120 inch pounds of torque.
4. Assemble to kart and install brake lines.
5. Bleed with dot-5 silicone brake fluid.

6.3 Master Cylinder Rebuild Instructions (Part #: 15251)

Disassembly:

1. Remove cotter pins and washers.
2. Drive pivot pin out with a drift pin to remove lever arm assembly.
3. Remove boot.
4. Hold down on m/c piston and remove piston and spring. If piston will not come out of the bore on it's own, remove the bottom fitting, then using a long, thin drift pin, go into the center of the piston so no damage to the m/c bore occurs.
5. Remove the cap screws and o'rings from cap.

Clean and inspect:

1. Clean all the parts in a cleaner such as mineral spirits.
2. Examine the bore for any unusual wear.
3. Sand bore by hand with # 600 grit sandpaper, recheck and clean.

Assembly:

1. Insert new cap screws into cap and push on new o'rings from the bottom side of the cap.
2. Start cap screws into place but leave loose, now pull new cap o'ring into place and tighten screws until cap pulls all the way down on body.
3. lubricate the bore with appropriate brake fluid
4. Put new spring in new piston and very carefully start seal down into bore with a rocking motion until seal passes the snap ring groove. This must be done very carefully!
5. Hold down on piston and install the new snap ring.
6. Install new boot.
7. Line up the lever arm and install new pivot pin.

8. Install new cotter pins and washers.
9. Pull on the lever arm all the way to be sure the spring has aligned properly in the piston. If it should feel like the action is not smooth, check position of the spring by looking through the fitting hole. Align if necessary using the thin drift pin.
10. Reinstall the fitting that may have been removed.
11. Master cylinder is now ready for use! Assemble on kart and bleed with dot 5, silicone fluid.

Again, keeping your brakes in proper working order should be one of your highest priorities so please take time to inspect your complete brake assembly **each week**. If you find **anything** suspicious or out of the ordinary, please take time to fix it or contact Phantom or Martin Custom Products. Either Phantom or MCP will be glad to inspect your system for problems *free of charge* to insure your safety so do not hesitate to return your system if you see a potential problem.

7.0 REAR AXLE POSITIONS

Your Phantom chassis allows you to adjust your rear ride height by adjusting the rear axle position. Most models of our chassis have 2 or 3 available positions for you to choose from. All karts are shipped in the most commonly used position, which is the “raised position” or with the axle in the lowest position. This can get a little confusing so please note the following... When you lower the axle, this raises the rear ride height of the chassis. When you raise the axle, this lowers the rear ride height of the chassis.

There are two main reasons you may want to change the axle position. One is ground clearance. For rougher tracks, you will raise the kart, lower the axle, to get enough ground clearance to miss the bumps. While on smooth tracks you can lower the kart, raise the axle, to reduce the weight transfer. That brings us to the second reason, weight transfer. As you increase the ground clearance of a chassis, you also increase the vertical CG, which creates more lateral weight transfer. Many racers use this as a tuning tool to increase or decrease side bite. For more information on this subject, get your copy of these Top Secret videos: *Top Secret* or *Scales: VCG and Chassis Dynamics*.

8.0 ADDING BALLAST WEIGHT (LEAD)

Another very important safety feature that many racers often-over look is how, where and how much ballast weight they are adding to the kart. Please note and adhere to the warning stickers on the frame and the embossed warning in the chassis weight brackets. **These brackets are designed to hold a maximum of 5 pounds per bracket!** Also note the recommended fasteners on the frame sticker. **Minimum 5/16” Grade 8 bolts with jam nut and safety pin!** These notices are for the safety of you, your competitors and the fans.

It is also very important that you *use a rubber grommet between the ballast weight and the chassis weight bracket*. This grommet will prevent the bracket from being damaged when you tighten the ballast weight to the bracket. Most ballast weight is made of lead. Because lead is softer than the steel bracket, when you tighten the lead weight directly to the bracket it will allow the bracket to pull up into the soft lead and bend the bracket. If you continually bolt the lead directly too the bracket without a grommet, it will cause the bracket to fail and break. So please take a few minutes to install a rubber grommet under each weight you bolt to you chassis.

9.0 ADJUSTABLE CASSETTE (UPGRADE)

The new Phantom adjustable cassette may quite possibly be the most user-friendly product that has hit the sport of karting in some time. If used properly, this adjustable cassette can save you valuable time both at the track and at the shop. Please take a minute to read over this section to insure you get the most out of this product.

The purpose of this adjustable cassette is to provide a way of fine-tuning your cross weight without having to alter the front of your kart. Many racers do not like to remove the front spindles once they have their toe and camber set to make a slight cross change. This cassette allows the racer to adjust the cross weight at the rear of the kart instead of the front.

Installing and using your adjustable cassette:

1. We recommend installing the adjustable cassette on the left rear, but it will work on the right rear if you wish.
2. Remove your standard cassette and install the new adjustable cassette as normal. (For Performance Rear Axle Bearings applications you will not use the Skezlok collar with this cassette. Use a regular axle collar on each side of the bearing instead. Refer to PRAB assembly instructions in section 5.1 of this manual for installing the bearing into the cassette properly. Be sure the proper length mounting bolts are installed in the proper location! Using longer bolts will interfere with the cassette's ability to adjust.)
3. After the cassette is completely installed, weigh the kart as normal with the center pin installed in the cassette. This insures that your axle is in the stock location.
4. **We do not recommend using the adjustable cassette to make major cross changes.** Set the cross weight close as possible with the front spindles and use the adjustable cassette only for fine tuning and track side adjustments.
5. To add cross to your kart simply loosen the four 1/4" SHCS with a 3/16" Allen wrench just enough to allow the cassette to adjust. Loosen the jam nut on the jack-bolt and screw the bolt down until you have the desired amount of cross weight. **One full turn should adjust approximately 2.2% of cross.**
6. Retighten the four 1/4" SHCS and jam lock the jack-bolt

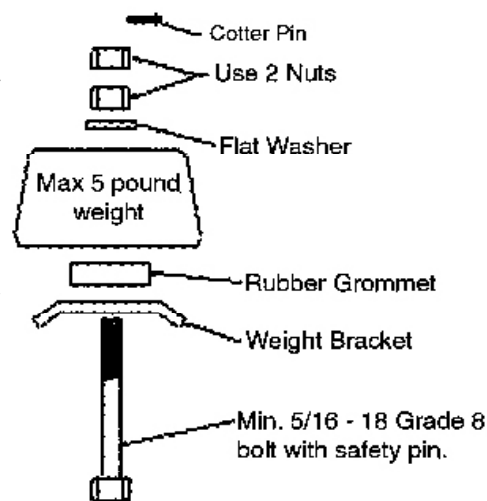

10.0 PAINT CARE AND CLEANING

Your new Phantom chassis is coated with a state of the art powder coating process to ensure your chassis will stay looking great for years to come. In order to get the maximum life and appearance out of your powder coated chassis, it's important to properly maintain your chassis surface. Just like any painted surface, it's important that you apply a coat of wax to protect the surface from scratching and fading. Depending on how often you race your kart, you should wax your chassis and it's components every 1 to 4 months. If you race your kart more often, you should wax it more often.

Be sure to wash your chassis between races with water and a mild detergent such as any of the popular car washing detergents. **It is not recommended to wash your chassis with high pressure.** High pressure can remove the paint and force water and dirt into all of the bearings on your kart. A gentle garden hose and some elbow grease will do just fine. **Do not use any high strength detergents or solvents to clean your chassis.** They will damage your paint by causing it to fade, crack and may even remove the paint all together. Using such detergents and solvents will also fade and/or remove the anodizing and oxidizing of the components.

After you have washed your kart, be sure to **apply a little surface oil to the black oxide parts** such as the rear axle, steering shaft, and peddle rods. WD-40, LPS, etc. works fine. These parts may begin to rust if they are not kept lubricated. While you're at it, you need to hit the chain with a little lube too or it will also rust.

Most electronics do not like to be washed. Unless your instruments such as your tachometer and lap timer are waterproof, you may want to remove it prior to washing. *(Just a suggestion)*

11.0 BENT OR BROKEN PARTS

If you race, you're going to get into wrecks and you're going to damage some parts. Before you repair those parts yourself, consider the safety factor. **Phantom Racing Chassis does not recommend repairing any parts that are damaged.** Each component on your kart is there for a reason and if that component does not work properly, it may be unsafe. Example, The nerf bars are there to act as a crush zone that will absorb energy when the kart is hit in the side. Once that bar has been crushed, it has done its job and needs to be replaced. If you straighten that bar and reuse it, it will not provide the same protection for the next hit. Please consider the safety of your driver before you put him/her back into competition with damaged parts. **After all, the final decision to the safety of your chassis rests on you every time your kart goes on the track!**

Racing is a dangerous sport. Wiggins Kart Shop, Inc. and/or Phantom Racing Chassis® is not liable for injuries that may occur while using any product/s we sell and/or manufacture. The final decision of the safety and use of any product is the responsibility of the user. The user accepts all responsibility. All products that are sold by Wiggins Kart Shop, Inc. and /or Phantom Racing Chassis® are intended for professional racing ONLY!

12.0 PERFORMANCE

Recommended Tire and Wheel Size

Due to the fact that our chassis are used all over the US, from the Saturday night bullrings, to the weeklong Grand National events, we simply cannot predict what type of situations you will encounter. Different track configurations and track surfaces will cause you to run the spectrum on tire sizes and compounds. The best advice we can give you on choosing the tires you should start with is to contact some of the racers that normally run at the track you are going to. Also, you should definitely contact the local Authorized Phantom Dealer that services that track for their recommendation. For more information about tires and how they work, check out the *Top Secret Video Club*. There are two videos dedicated to kart tires.

Below are some recommended wheel widths to start with on your new Phantom Chassis. Once you have raced your chassis a few times, you may find that using a different size may work better for you, so do not be afraid to try. For more information about how wheel sizes affect the handling of your chassis, join the *Top Secret Video Club*.

Asphalt Oval Tracks (all classes)	Dirt Oval Tracks (Jr. Classes)	Dirt Oval Tracks (Adult Classes)
LF – 6” RF – 10”	LF – 6 ½” RF – 10”	LF – 6 ½” RF – 10”
LR – 6” RR – 10”	LR – 8 ¼” RR – 10”	LR – 8 ¾” RR – 10”

13.0 SERIAL NUMBERS

It's important to locate and record your serial number as soon as possible. Please write it on the front of this manual as well as on your registration card. When you send us the registration card, we will send you a bottom nose decal as a thank you. We will also keep your number on file for you. With this number you will gain access to personalized setup assistance and other technical advice not available to non-Phantom drivers. You can register a new or used kart. If you can't find your registration card, you can register on our website or over the telephone.

Serial Number Locations

All serial numbers are a 6 digit number. They do not begin with “6” or “PN” or “11”. They are on a silver plate unless otherwise noted.

Stalker: LR Bearing Hanger (etched in frame)

Banshee: 97 - Mid 98: Left Rear Bearing Hanger (etched)

98 - 2000: Lower Steering Support (etched in frame)

01 - 02: Master Cylinder Brake Bracket

Gauntlet: 1999: Right Front Caster Plate (etched in frame)

Nemesis: 2000: Right Front Caster Plate (etched in frame)

01 - 04: Master Cylinder Brake Bracket

Phenom: 2004: Left Rear Axle meets Frame

Lil' Buggy: 2002-03: Master Cylinder Brake Bracket

Big Buggy: 2002-03: Master Cylinder Brake Bracket

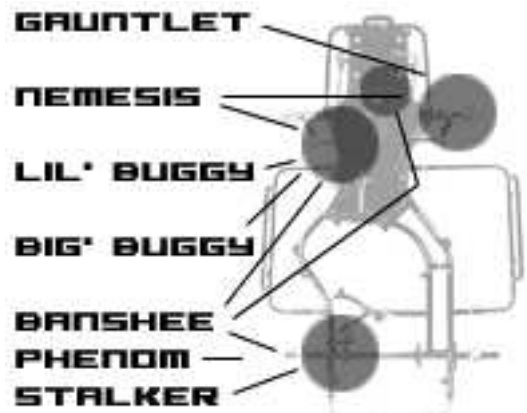

Setup Sheet for Phantom Phenom

Jr. Sportsman 1&2

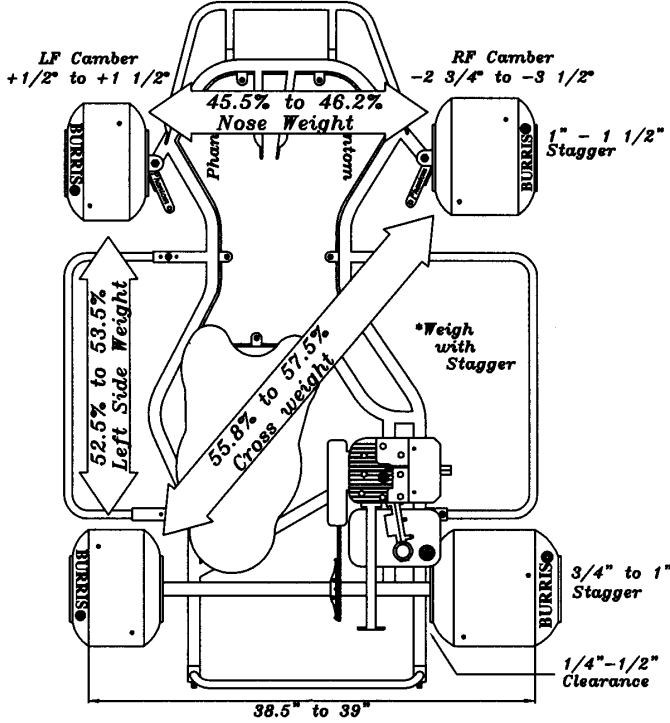

Jr. Rest. and Jr. Stock

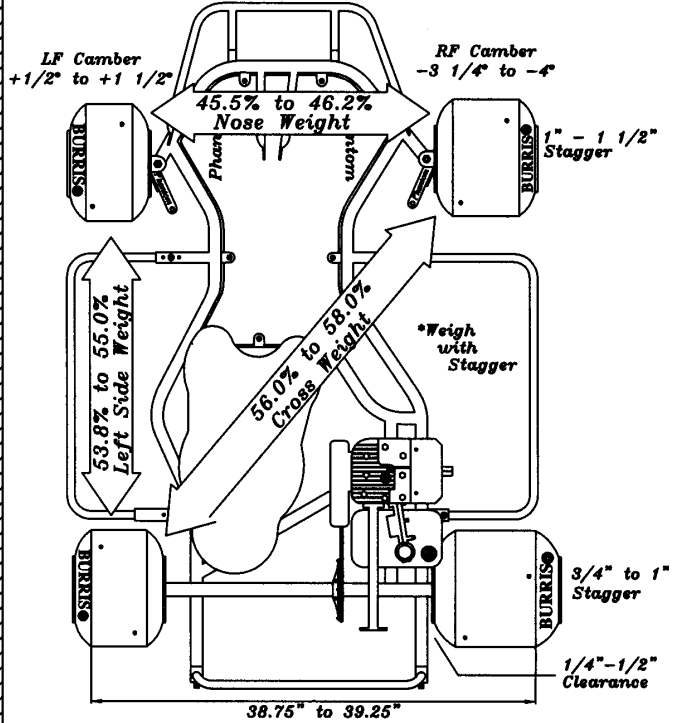

Revised Dec. 03

Adult Stock

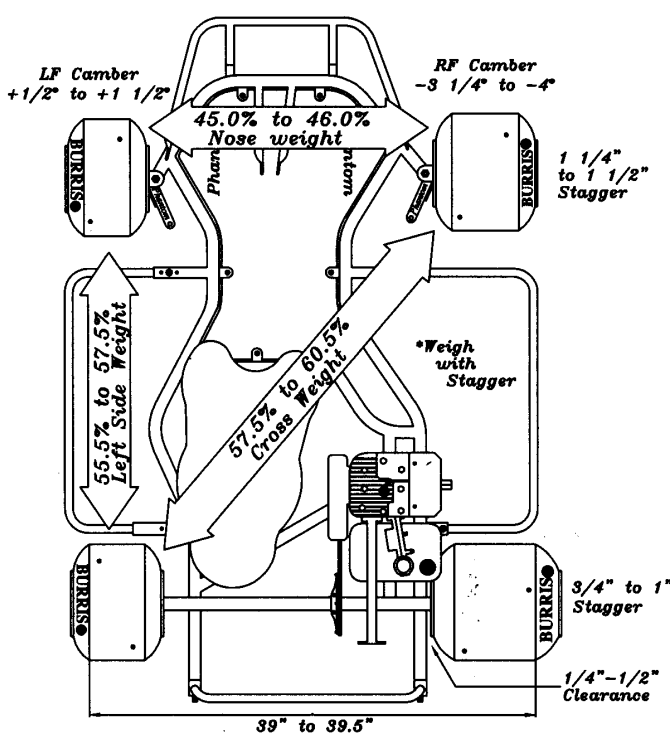

Adult Modified

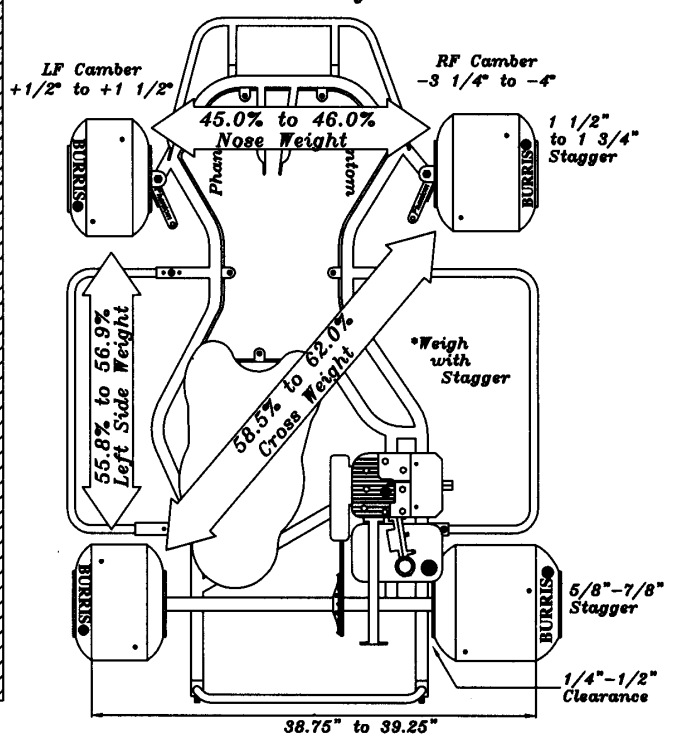

Please note that these are only suggested starting points for your setup. You may find that another setup will work better for you in your situation. Also, your local Authorized Phantom Dealer can assist you in customizing your setup to your track.



Gear Ratio Chart

Phantom Racing Chassis

Front Sprocket

Rear Sprocket	Front Sprocket														
	15	16	17	18	19	20	21	22	23	24	25	26	27	28	29
54	6.00	5.40	4.91	4.50	4.15	3.88	3.60	3.38	3.18	3.00	2.84	2.70	2.57	2.45	2.35
56	6.22	5.60	5.09	4.67	4.31	4.00	3.73	3.50	3.29	3.11	2.95	2.80	2.67	2.55	2.43
58	6.44	5.80	5.27	4.83	4.46	4.14	3.87	3.63	3.41	3.22	3.05	2.90	2.76	2.64	2.52
60	6.67	6.00	5.45	5.00	4.62	4.29	4.00	3.75	3.53	3.33	3.16	3.00	2.86	2.73	2.61
62	6.89	6.20	5.64	5.17	4.77	4.43	4.13	3.88	3.65	3.44	3.26	3.10	2.95	2.82	2.70
64	7.11	6.40	5.82	5.33	4.92	4.57	4.27	4.00	3.76	3.56	3.37	3.20	3.05	2.91	2.78
66	7.33	6.60	6.00	5.50	5.08	4.71	4.40	4.13	3.88	3.67	3.47	3.30	3.14	3.00	2.87
68	7.56	6.80	6.18	5.67	5.23	4.86	4.53	4.25	4.00	3.78	3.58	3.40	3.24	3.09	2.96
70	7.78	7.00	6.36	5.83	5.38	5.00	4.67	4.38	4.12	3.89	3.68	3.50	3.33	3.18	3.04
72	8.00	7.20	6.55	6.00	5.54	5.14	4.80	4.50	4.24	4.00	3.79	3.60	3.43	3.27	3.13
74	8.22	7.40	6.73	6.17	5.69	5.29	4.93	4.63	4.35	4.11	3.89	3.70	3.52	3.36	3.22
76	8.44	7.60	6.91	6.33	5.85	5.43	5.07	4.75	4.47	4.22	4.00	3.80	3.62	3.45	3.30
78	8.67	7.80	7.09	6.50	6.00	5.57	5.20	4.88	4.59	4.33	4.11	3.90	3.71	3.55	3.39
80	8.89	8.00	7.27	6.67	6.15	5.71	5.33	5.00	4.71	4.44	4.21	4.00	3.81	3.64	3.48
82	9.11	8.20	7.45	6.83	6.31	5.86	5.47	5.13	4.82	4.56	4.32	4.10	3.90	3.73	3.57
84	9.33	8.40	7.64	7.00	6.46	6.00	5.60	5.25	4.94	4.67	4.42	4.20	4.00	3.82	3.65
86	9.56	8.60	7.82	7.17	6.62	6.14	5.73	5.38	5.06	4.78	4.53	4.30	4.10	3.91	3.74
88	9.78	8.80	8.00	7.33	6.77	6.29	5.87	5.50	5.18	4.89	4.63	4.40	4.19	4.00	3.83
90	10.00	9.00	8.18	7.50	6.92	6.43	6.00	5.63	5.29	5.00	4.74	4.50	4.29	4.09	3.91
92	10.22	9.20	8.38	7.67	7.08	6.57	6.13	5.75	5.41	5.11	4.84	4.60	4.38	4.18	4.00
94	10.44	9.40	8.55	7.83	7.23	6.71	6.27	5.88	5.53	5.22	4.95	4.70	4.48	4.27	4.09
96	10.67	9.60	8.73	8.00	7.38	6.86	6.40	6.00	5.65	5.33	5.05	4.80	4.57	4.36	4.17
98	10.89	9.80	8.91	8.17	7.54	7.00	6.53	6.13	5.76	5.44	5.16	4.90	4.67	4.45	4.26
100	11.11	10.00	9.09	8.33	7.69	7.14	6.67	6.25	5.88	5.56	5.26	5.00	4.76	4.55	4.35

Phantom Kart Note Pad



Chassis Weigh-out Sheet

Chassis- _____ Class- _____
 Driver- _____ Date- _____

WWW.PHANTOMCHASSIS.COM

- ICON**
- Phenom**
- NEMESIS**
- Banshee**

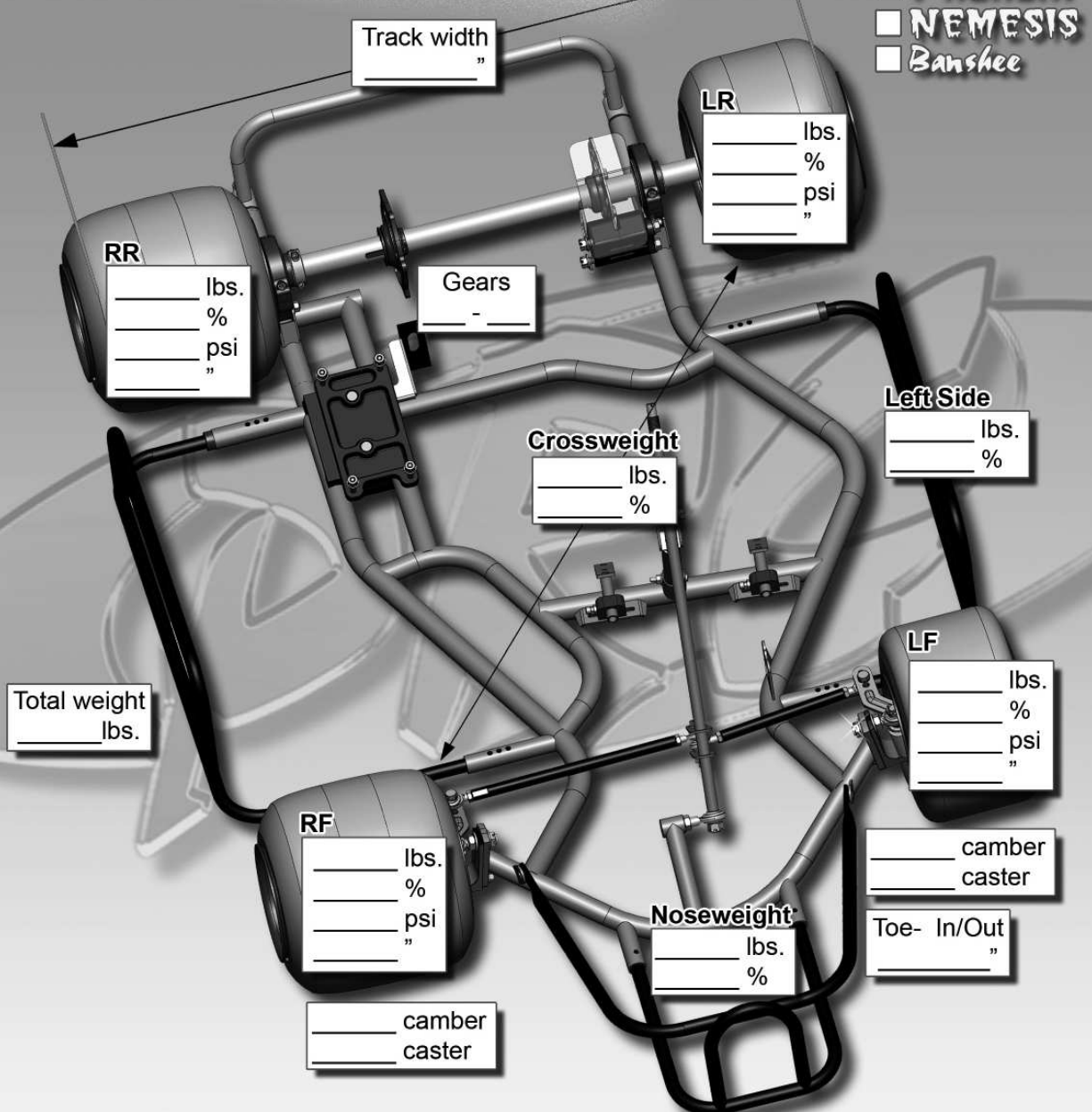

Notes: _____

NOTES

WIGGINS KART SHOP INC.
4010 HWY 152 WEST • CHINA GROVE, NC 28023
TEL: 704-855-3165 • FAX: 704-857-5819

WWW.PHANTOMCHASSIS.COM

version P-20040209